

# GMN

## High Precision Ball Bearings



40000307

# QUALITY MANAGEMENT

The quality policy of **GMN Paul Müller Industrie GmbH & Co. KG**, is based on the principle to offer the best possible solutions to all demands of our customers and to get and keep the confidence and satisfaction of our customers.

The target of delivering perfect products to our customers includes a careful handling of all related treatments and services.

The company satisfies the requirements to be state of the art referring products, treatments and services.



All divisions of **GMN Paul Müller Industrie GmbH & Co. KG** (motion-technology, high precision ball bearings and spindle technology) are certified in accordance with DIN EN ISO 9001:2000.



In Nürnberg, **GMN Paul Müller Industrie GmbH & Co. KG** produces with an experience of more than 95 years high precision ball bearings, machining spindles, free-wheel clutches, non-contact seals and air bearings for a wide scope.

Most of the products are made for special applications on customer requests.

A world wide net of service stations support all demands of our customers.

**GMN** is the trademark of **GMN Paul Müller Industrie GmbH & Co. KG**.

This catalog reflects the latest design features at the time of printing. The company reserves the right to change designs and specifications at any time.

Reprint, photomechanical reproductions as well as reproduction from clippings only with license of **Paul Müller Industrie GmbH & Co. KG**.



GMN Paul Müller Industrie GmbH & Co. KG  
Catalogue  
High Precision Ball Bearings

Catalogue No. 40000307

### Technical information

#### ... about the product

- Spindle ball bearings · Deep groove ball bearings · Boundary dimensions 6
- Bearing series spindle ball bearings 7-10
- Cages 11
- Seals, materials 12
- Hybrid bearings with ceramic balls 13-15
- Precision classes and tolerance tables 16-20

#### ... for design of the bearing application

- Preload, rigidity, lift-off force 21-23
- Bearing arrangements 24-29
- Lubrication 30-31
- Accuracy of associated components 32-33

#### ... for bearing calculation

- Method of calculation 34
- Nominal and modified lifetime 35
- Static load rating 36
- Service life of the grease 37
- Limiting speed 38-39

#### ... for assembly

- Basic rules for storage and assembly 40
- Failure analysis 40

### Bearing tables

#### Spindle bearings

- Designation code 41
- Interchangeability chart 42
- Explanation of notations 43
- Bearing characteristics 44-61

#### Deep groove bearings

- Designation code 62
- Explanation of notations 63
- Bearing characteristics 64-65

### Special solutions

#### General

- Special bearings/units 66
- Technology 66
- Engineering / Service 66

#### Example applications

- Vacuum technology 67
- Touchdown bearings 67
- Measurement technology 67
- Machine tools 67

### Appendix

- Dictionary English – German 68-70

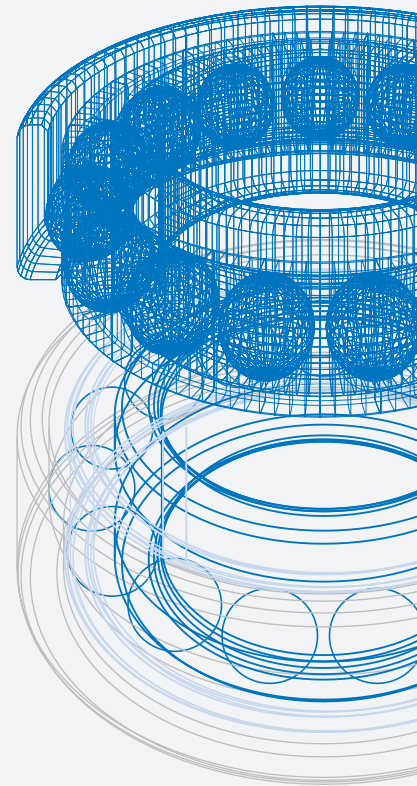

Should this catalogue leave any questions unanswered ...

... then our product engineering expertise is here to help you.

Whether you have questions regarding application, availability, load, speed or correction factors – we will be pleased to assist you in obtaining the optimum from our bearings.

Please call us: +49 (0) 9 11 - 56 91 - 2 25/2 29/2 17/3 26  
Telefax: +49 (0) 9 11 - 56 91 - 5 87  
E-Mail: [vertrieb.kula@gmn.de](mailto:vertrieb.kula@gmn.de)

## Spindle bearings

Spindle bearings are angular contact bearings.

### Characteristics

- Support of axial load in one direction only
- Adjustment against a second bearing is necessary
- Higher ball complement than with deep groove bearings
- High rigidity and loading capacity
- Suitable for high speeds

The forces are transmitted from one raceway to the other under a specific contact angle.

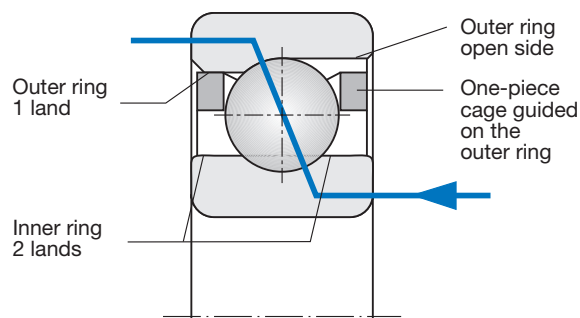

## Deep groove bearings

Deep groove bearings are radial deep groove ball bearings

### Characteristics:

- Support of axial and radial loads in both directions
- Suitable for high speeds

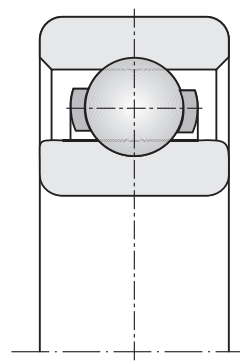

## Boundary dimensions

The boundary dimensions of ball bearings conform to the boundary dimensions laid down in DIN, ISO and ABMA Standards.

Depending on the series each bore size comes in several outside diameters and widths.

Series offered by GMN:

- Spindle bearing: 618..,619..,60..,62..
- Deep groove bearing: 60.., 62..

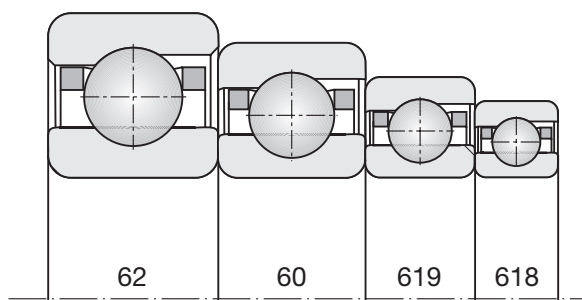

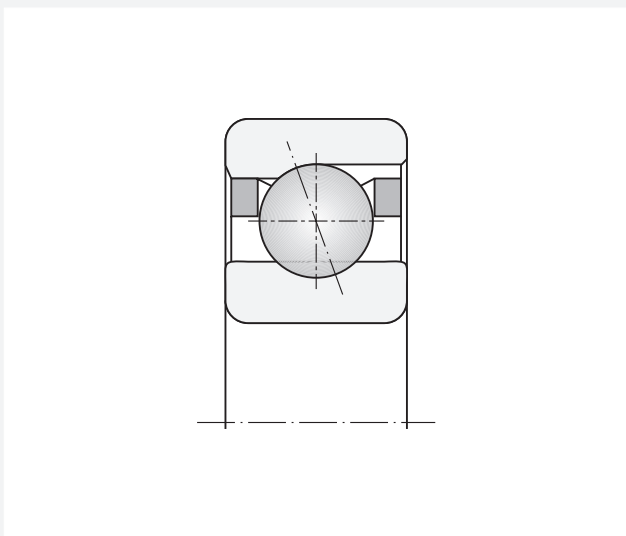

## Bearing series S...

- GMN standard spindle bearing
- Non-separable type

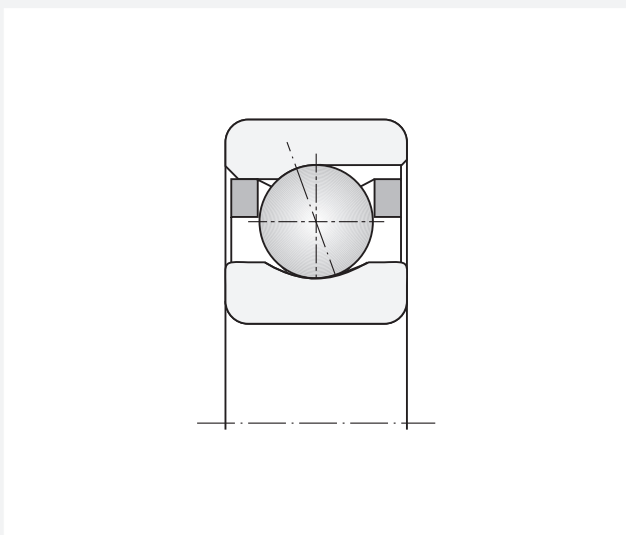

## Bearing series SM ...

- Geometry of inner ring modified for extremely high speeds
- Smaller load rating and static rigidity compared to bearing series S ...
- Equal or higher service life as with bearing series S ... due to lower friction
- Non-separable type

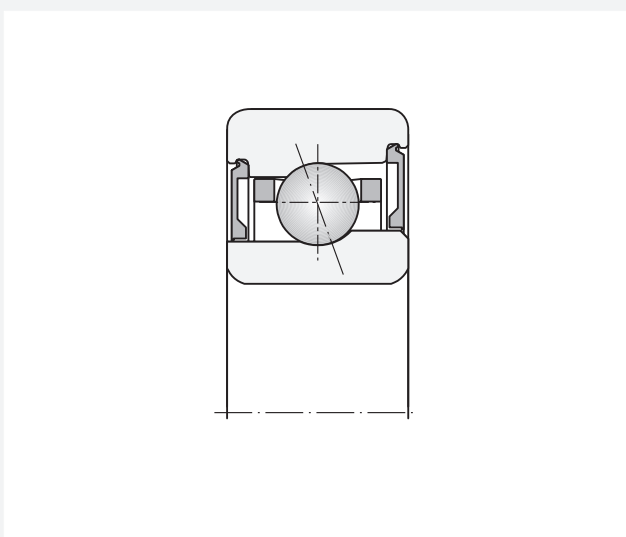

## Bearing Series KH ...

- Optimised spindle bearing for extremely high speeds and increased service life
- Smaller load rating and static rigidity compared to bearing series SM
- Sealed, with for-life lubrication or open for oil lubrication
- Non-separable type

## Bearing series SH ...

A special design of series SM ..

- Optimised oil feeding, one land in inner ring
- Speed coefficient  $n \times d_m = 2.4 \cdot 10^6$  mm/min reliably possible with cooling lubrication
- Non-separable type
- Available only on request

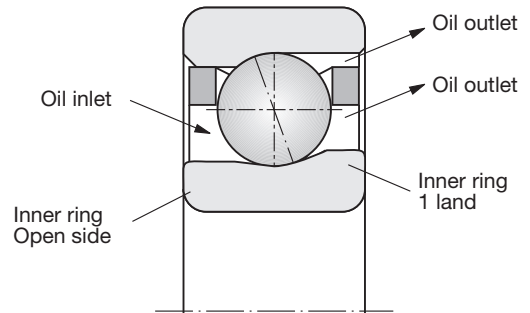

Bearings of this series are only available to precision classes HG, UP, P2 and ABEC 9

## Bearing series SMA ...

Special design of series SM

- Oil feed via outer ring
- Optimised for oil-minimized lubrication and extremely high speeds
- High degree of reliability in operation is ensured by force-feed lubrication
- Non-separable type
- Only available on request

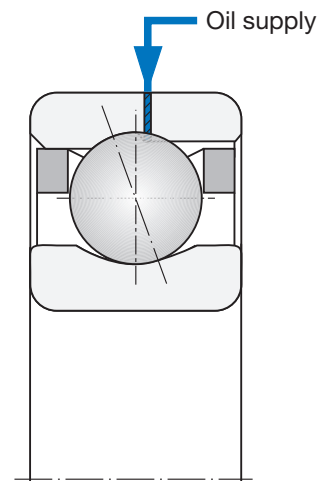

## Bearing series SMI ...

A special design of series SM

- Oil feed via inner ring
- Optimised for oil-minimized lubrication and extremely high speeds.
- High degree of reliability in operation is ensured by force-feed lubrication
- Non-separable type
- Available only on request

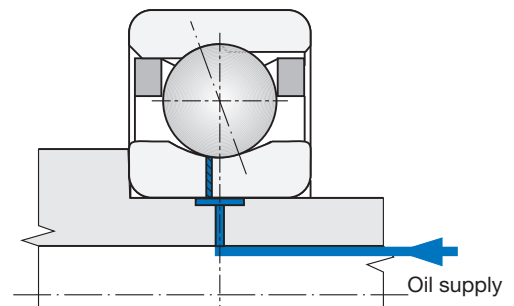



## Separable type

- Simple mounting due to separate installation of inner and outer ring (when necessary).
- Balancing of rotating components with installed inner ring.
- A defined axial clearance of the bearing system is possible.

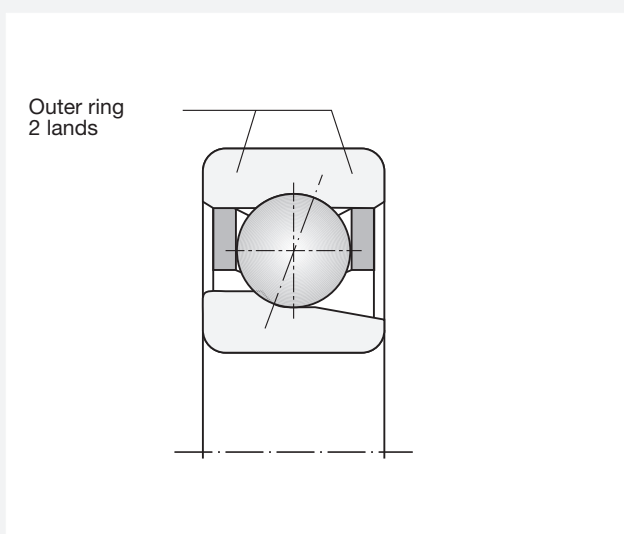
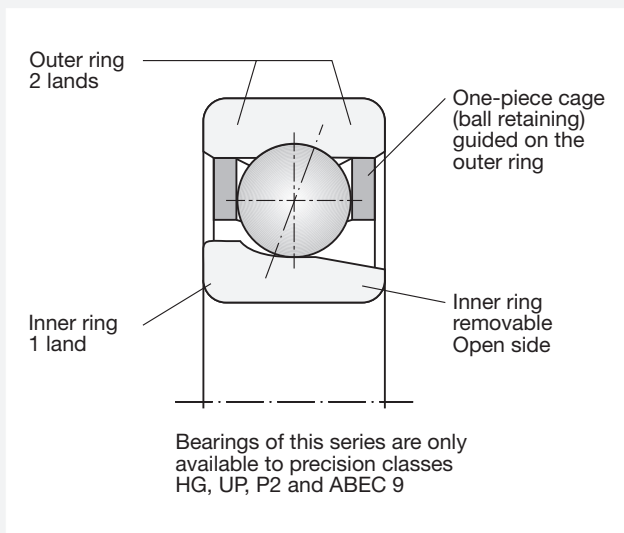

## Bearing series BHT ...

- The cage retains the balls in the outer ring, which means the balls do not fall out when the one-land inner ring is removed.
- The one-piece cage is guided on both lands of the outer ring.
- The contact conditions are the same as with bearing series SM ...
- Due to the ball retaining design of the cage, the ball complement is less than for bearing series SM.

## Bearing series BNT ...

- Corresponds essentially to bearing series BHT ...
- However the contact conditions are the same as for bearing series S ...
- Due to the ball retaining design of the cage, the ball complement is less than for bearing series S ...

## Special bearing design

Available only on request

### Bearing series ...X and BHT ...X

- Non-separable type
- High-precision ball bearings of extra wide design with shields on both sides for high speed and grease lubrication are used in drilling, milling or grinding spindles for special operating conditions.
- The non-contact shields form a labyrinth seal together with the recess in the inner ring.
- The bearing friction is scarcely influenced by this. Due to the labyrinth seal, the lubricant is retained in the bearing so that the bearing can achieve long running times, corresponding to operating speeds, with only one grease fill (for-life lubrication).

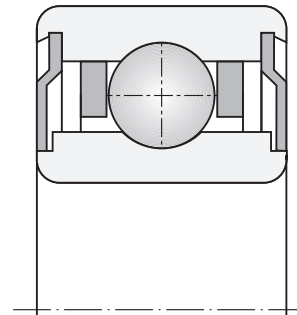

... X

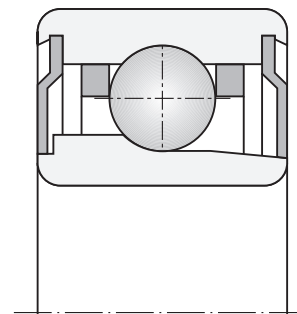

BHT... X

### Bearing series S ...TB, SN ...TA

With grease lubricated spindle bearings and cage guided on one land, cage vibration can be generated at critical speed ranges.

There are two other alternatives in addition to the **TXM** cage that is proven against cage vibrations:

- 1. Use of TB- cage with bearing series S...

The cage is guided on the inner ring by two lands.

Smaller load rating and static rigidity than bearings with TA or TXM cages.

- 2. Use of TA-cage with bearing series SN ...

The cage is guided on the outer ring by two lands. The contact conditions are the same as with bearing series SM...

Please contact GMN for selection of these bearing designs.

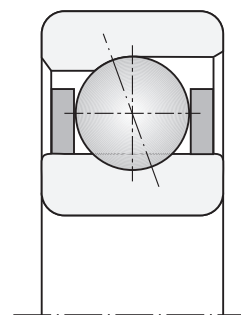



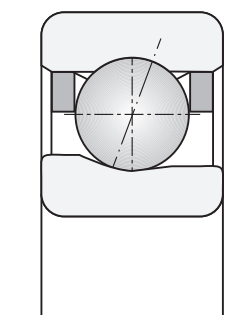

S...TB







SN...TA

## Cages for spindle bearings

Cage	TA 	TXM 	TAM 	TB 
<b>Material</b>	Textile reinforced phenolic resin	Polyetheretherketone (PEEK), thermoplast, carbon fibre reinforced	Textile reinforced phenolic resin	Textile reinforced phenolic resin
<b>Permissible operating temperature</b>	120 °C	250 °C	120 °C	120 °C
<b>Cage guidance</b>	On outer ring	On outer ring ball retaining	On outer ring ball retaining	On inner ring
<b>Manufacture</b>	Machined	Moulded	Machined	Machined
<b>Notes</b>	Standard cage	Developed for grease lubrication  Grease remains in the ball/cage area; High service life, high resistance to wear; good alternative for cage vibrations		Smaller load rating than bearing with TA cage
<b>Mounting</b>	For bearing series S, SM, KH, SH, SMI and SMA	For bearing series S and SM	For bearing series BHT and BNT	On request

Cages made of special material with special treatment like Torlon, aluminium bronze as well as special designs are available on request.

## Cages for deep groove bearings

Cage	T9H 	TBH 	J 	TA, TB 
<b>Material</b>	Glass-fibre reinforced polyamide	Textile reinforced phenolic resin	Strip steel	Textile reinforced phenolic resin
<b>Permissible operating temperature</b>	140 °C	120 °C	220 °C	120 °C
<b>Design</b>	One piece, crown type	One piece, crown type	Two piece, clamped or riveted	Two piece, riveted

Cages made of special material like aluminium bronze, Canevasit, Torlon, PEEK and others are available on request.

## Seals

For long maintenance-free operation, deep groove bearings and spindle bearings are charged with lubricant ready for operation (for-life lubrication) and shielded/sealed.

Spindle bearings are fitted with non contact "RZ" seals and deep groove bearings are fitted with "Z" metal shields (fixed in the outer ring by means of snap rings).

## Advantages

- Simple design possible
- Protection against foreign particles
- Protection against the escape of lubricant

## Materials

### Ball bearing - Rings

- Standard:  
Vacuum degassed chrome steel 100 Cr 6  
(is equivalent to material no. 1.305, SAE 52100, SUJ2)  
Heat treated for operating temperatures up to 150 °C
- HNS-Steel (High Nitrogen Steel):  
For applications which demand
  - higher speeds
  - higher resistance to wear
  - higher loading capacity
  - higher resistance to heat
  - higher corrosion resistance  
(on request)
- For higher temperatures up to 500 °C:  
High temperature steel (on request)

### Balls

- Standard:  
Vacuum degassed chrome steel 100 Cr 6  
(is equivalent to material no. 1.305, SAE 52100, SUJ2)
- Ceramic material silicon nitride  $\text{Si}_3\text{N}_4$
- For higher temperatures up to 500 °C:  
High temperature steel (on request)

## Hybrid bearings with ceramic balls

**Hybrid ball bearings** with steel rings and ceramic balls have today become indispensable for many advanced applications. The advantages have been clearly demonstrated in numerous trials and successful use in the field.

### Properties of ceramic

The ceramic material silicon nitride  $\text{Si}_3\text{N}_4$  is excellent for use in precision ball bearings. A comparison between silicon nitride and conventional bearing steel 100 Cr 6 is shown in diagram 1.

Further advantages of ceramic are:

- Low chemical affinity to 100 Cr 6
- Low friction coefficient
- Little heat transfer
- Corrosion resistant
- Non-magnetic
- Electrically isolating

### Advantages for the user

#### Longer service life

Experience shows that **double the service life** in comparison to conventional bearings can be reached by using hybrid bearings. Depending on the operating conditions life times rates still higher can be achieved.

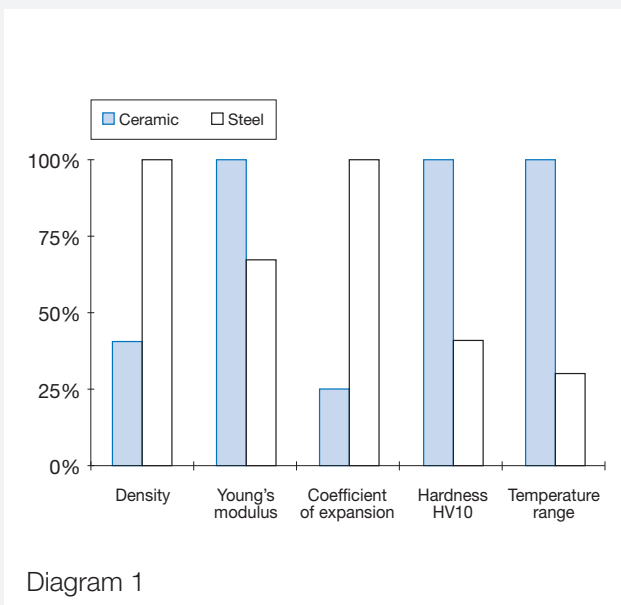

Properties (at ambient temperature)	Unit	Ceramic $\text{Si}_3\text{N}_4$	Ball bearing steel 100 Cr 6
Density	$\text{g/cm}^3$	3.2	7.8
Coefficient of expansion	$10^{-6}/\text{K}$	3.2	11.5
Young's modulus	GPa	315	210
Poisson's ratio	–	0.26	0.3
Hardness (Vickers) HV10	–	1600	700
Tensile strength	MPa	700	2500
Fracture toughness	$\text{MPa m}^{0.5}$	7	20
Thermal conductivity	$\text{W/mK}$	30-35	40-45
Spec. electric resistance	$\Omega\text{mm}^2/\text{m}$	$10^{17} - 10^{18}$	0,1 - 1

Properties of silicon nitride and ball bearing steel

The reasons for this are:

- **Low surface adhesive wear**  
The lower affinity to steel reduces the adhesive wear, which is caused by the cold welding effect on irregularities in the raceway and ball surface.
- **Low abrasive wear out**  
With steel balls, contaminants and particles from the process of running in are embedded into the surface. With every revolution of the ball, these foreign particles damage the raceway. These particles make little impact on the extremely hard ceramic ball.
- **Insensitivity to poor lubrication**  
Low adhesion and friction allow the hybrid bearing to perform well even under poor lubrication.
- **Longer grease service life**  
Lower operating temperature and favourable tribological features, extend the service life of the grease.

## Higher speeds

The attainable speeds depend above all on the thermal conditions in the bearing. Because of lower friction, the hybrid bearing generates less power loss. Therefore the speed limit is increased dramatically. Depending on the application, speed rises of up to 30 % are possible compared to bearings with steel balls.

- **Low rolling friction**

The rolling friction is reduced, as the centrifugal force of the lighter ceramic ball is less. The contact ellipse is less because of the higher Young's modulus.

- **Low sliding friction between ball and raceway**

At high speeds, sliding friction is responsible for most of the total friction.

One of the criteria for the sliding friction is a low spin/roll ratio.

The service life is negative affected by values above 0.25.

Diagram 2 shows the advantages of ceramic balls.

- **Avoid ball skidding**

The balls skid on the raceway if the preload between the rings is too small. This negative process usually occurs in case of an insufficient preload of the bearing or an excessive acceleration. With hybrid bearings the minimum preload can be reduced as they have a smaller inertia and generate a smaller spinning moment.

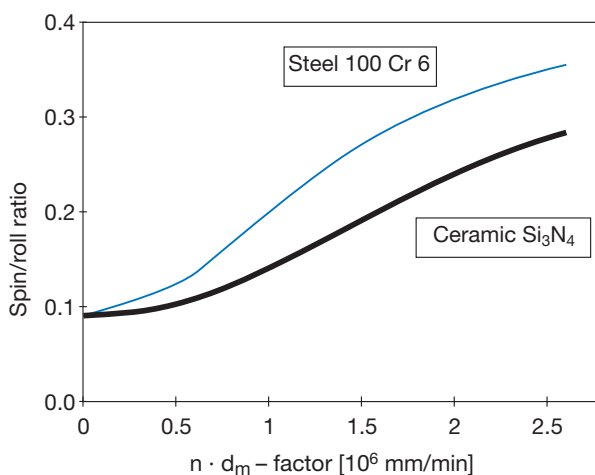

Diagram 2

## Low cost lubrication

- **Grease lubrication** can be used in higher speed ranges.
- The limiting speed for minimum **oil lubrication increases** significantly. In many cases, it can replace the expensive oil jet lubrication.

## Higher rigidity

- The radial rigidity of hybrid bearings is approximately 15% higher at low speeds because of the higher Young's modulus.
- With higher speeds, the centrifugal force affects the internal load distribution and the dynamic rigidity is reduced. Diagram 3 shows reduced loss of rigidity for hybrid bearings.
- A high rigidity improves the accuracy and shifts the critical fundamental frequency of the bearing arrangement.

## Improved machining accuracy

The following factors lead to an improvement of the surface quality and accuracy of machined parts.

- Higher rigidity of bearing arrangement
- Small thermal expansion
- Low vibration impulse by ceramic balls

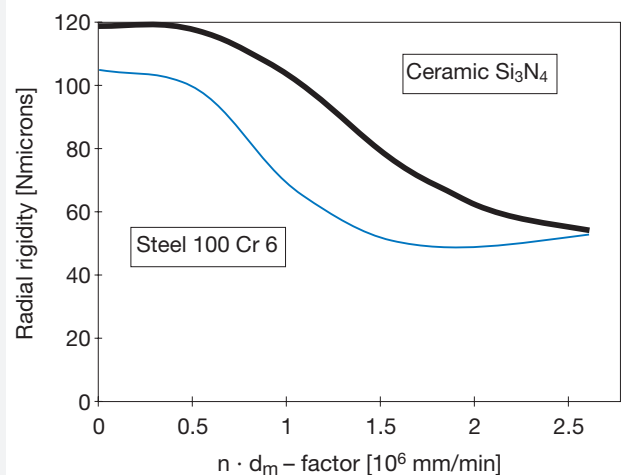

Diagram 3

## Load ratings

DIN/ISO standards do not specify any calculation methods for the determination of load ratings of hybrid bearings. If the classical fatigue theory is used, the load ratings and the service life will be lower than those for steel balls. However, experience shows that the actual service life is significantly longer. Due to this, GMN uses the same load ratings as for conventional bearings.



## Examples of application

- **Spindles for machine tools:**  
State of the art machining processes like high speed milling require a new concept of bearing arrangement for spindles. The application of hybrid bearings has resulted in a remarkable improvement of performance. For some years we at GMN have successfully used many spindles with hybrid bearings for our own production processes.
- **Special bearing arrangements:**  
With vacuum pumps, reliability of the bearings is of utmost importance, as breakdown can result in high costs.

### More applications are:

- Medical equipment like X-ray tube bearings
- Touchdown bearings for magnetic bearings
- Bearings for aeronautic and aerospace

## Summary

When conventional bearings fail, the technological and economical solution is often to use hybrid bearings. It is important always to take the whole system into consideration and to carry out a "weak point" analysis. GMN is pleased to share its knowledge on this subject with you.

## Precision classes and tolerance tables

The tolerances for dimensional, form and running accuracy of GMN high precision ball bearings are specified in international (ISO 492) and national standards (DIN 620). GMN high precision bearings are manufactured to precision class 4 and class 2 (P4 and P2) as well as ABEC 7 and ABEC 9.

For special applications, e.g. vacuum pumps, gyroscopes as well as measuring engineering and optical systems, GMN manufacture bearings to the internal tolerance classes HG (high precision) and UP (ultra precision). Apart from the requirements mentioned, the tolerance classes contain additional selection criteria.

### Innen ring limits in micron

d bore diameter, nominal [mm]	over to	2,5 10	10 18	18 30	30 50	50 80
$\Delta_{dmp}$ deviation of a single mean bore diameter	P4 HG UP P2	0-4.0 0-3.0 0-3.0 0-2.5	0-4.0 0-3.0 0-3.0 0-2.5	0-5.0 0-3.0 0-3.0 0-2.5	0-6.0 0-5.0 0-3.0 0-2.5	0-7.0 0-5.0 0-4.0 0-4.0
$\Delta_{ds}$ bearing series 60, 62 variation of a single bore diameter	P4 HG UP P2	0-4.0 0-3.0 0-3.0 0-2.5	0-4.0 0-3.0 0-3.0 0-2.5	0-5.0 0-3.0 0-3.0 0-2.5	0-6.0 0-5.0 0-3.0 0-2.5	0-7.0 0-5.0 0-4.0 0-4.0
$V_{dp \max}$ bearing series 618, 619 variation of bore diameter in a single radial plane – out of roundness	P4 HG UP P2	4.0 3.0 3.0 2.5	4.0 3.0 3.0 2.5	5.0 3.0 3.0 2.5	6.0 5.0 3.0 2.5	7.0 5.0 4.0 2.5
$V_{dp \max}$ bearing series 60, 62 variation of bore diameter in a single radial plane – out of roundness	P4 HG UP P2	3.0 3.0 3.0 2.5	3.0 3.0 3.0 2.5	4.0 3.0 3.0 2.5	5.0 5.0 3.0 2.5	5.0 5.0 4.0 4.0
$V_{dmp \max}$ variation of mean bore diameter in several planes – taper	P4 HG UP P2	2.0 2.0 2.0 1.5	2.0 2.0 2.0 1.5	2.5 2.0 2.0 1.5	3.0 3.0 2.0 1.5	3.5 3.0 2.5 2.0
$K_{ia \max}$ radial runout of assembled bearing inner ring	P4 HG UP P2	2.5 2.0 1.5 1.5	2.5 2.0 1.5 1.5	3.0 2.0 1.5 2.5	4.0 2.0 2.0 2.5	4.0 3.0 2.0 2.5
$S_{d \max}$ inner ring reference face runout with bore – side runout	P4 HG UP P2	3.0 3.0 2.0 1.5	3.0 3.0 2.0 1.5	4.0 3.0 2.0 1.5	4.0 4.0 2.0 1.5	5.0 4.0 2.0 1.5
$S_{ia \max}$ assembled bearing inner ring face runout with raceway – axial runout	P4 HG UP P2	3.0 3.0 2.0 1.5	3.0 3.0 2.0 1.5	4.0 4.0 2.5 2.5	4.0 4.0 2.5 2.5	4.0 4.0 2.5 2.5
$\Delta_{BS}$ single bearing deviation of a single width of the inner ring – width tolerance	P4 HG UP P2	0- 40 0- 40 0- 25 0- 40	0- 80 0- 80 0- 80 0- 80	0-120 0-120 0-120 0-120	0-120 0-120 0-120 0-120	0-150 0-150 0-150 0-150
$\Delta_{BS}$ matched bearing deviation of a single width of the inner ring – width tolerance	P4 HG UP P2	0-250 0-250 0-250 0-250	0-250 0-250 0-250 0-250	0-250 0-250 0-250 0-250	0-250 0-250 0-250 0-250	0-250 0-250 0-250 0-250
$V_{BS \max}$ inner ring width variation	P4 HG UP P2	2.5 2.0 2.0 1.5	2.5 2.0 2.0 1.5	2.5 2.0 2.0 1.5	3.0 2.0 2.0 1.5	4.0 2.0 2.0 1.5



All GMN high precision ball bearings are also available in compliance with the American ABMA standards. The relationship between the various STANDARDS is explained below.

ISO	DIN	ABMA
class 4	P4	ABEC7
class 2	P2	ABEC9

The following tolerance symbols are laid down in DIN ISO 1132-1.

## Outer ring limits in micron

D outside diameter, nominal (mm)	over to	6 18	18 30	30 50	50 80	80 120
$\Delta_{D_{mp}}$ deviation of a single plane mean outside diameter	P4 HG UP P2	0-4.0 0-3.0 0-3.0 0-2.5	0-5.0 0-3.0 0-3.0 0-4.0	0-6.0 0-3.0 0-3.0 0-4.0	0-7.0 0-4.0 0-4.0 0-4.0	0-8.0 0-4.0 0-4.0 0-5.0
$\Delta_{D_s}$ bearing series 60, 62 variation of a single outside diameter	P4 HG UP P2	0-4.0 0-3.0 0-3.0 0-2.5	0-5.0 0-3.0 0-3.0 0-4.0	0-6.0 0-3.0 0-3.0 0-4.0	0-7.0 0-4.0 0-4.0 0-4.0	0-8.0 0-4.0 0-4.0 0-5.0
$V_{Dp \max}$ bearing series 618, 619 variation of outside diameter in a single radial plane – out of roundness	P4 HG UP P2	4.0 2.0 2.0 2.5	5.0 2.0 2.0 4.0	6.0 2.0 2.0 4.0	7.0 4.0 4.0 4.0	8.0 4.0 4.0 5.0
$V_{Dp \max}$ bearing series 60*, 62* variation of outside diameter in a single radial plane – out of roundness	P4 HG UP P2	3.0 2.0 2.0 2.5	4.0 2.0 2.0 4.0	5.0 2.0 2.0 4.0	5.0 4.0 4.0 4.0	6.0 4.0 4.0 5.0
$V_{Dmp \max}$ variation of mean outside diameter in several planes – taper	P4 HG UP P2	2.0 1.0 1.0 1.5	2.5 1.0 1.0 2.0	3.0 1.0 1.0 2.0	3.5 2.0 2.0 2.0	4.0 2.0 2.0 2.5
$K_{ea \max}$ radial runout of assembled bearing outer ring	P4 HG UP P2	3.0 2.0 2.0 1.5	4.0 2.0 2.0 2.5	5.0 2.0 2.0 2.5	5.0 3.0 3.0 4.0	6.0 3.0 3.0 5.0
$S_{D \max}$ variation of outside surface generatrix inclination with outer ring reference face – side runout	P4 HG UP P2	4.0 4.0 2.0 1.5	4.0 4.0 2.0 1.5	4.0 4.0 2.0 1.5	4.0 4.0 2.0 1.5	5.0 5.0 2.5 2.5
$S_{ea \max}$ assembled bearing outer ring face runout with raceway – axial runout	P4 HG UP P2	5.0 5.0 2.0 1.5	5.0 5.0 2.0 2.5	5.0 5.0 2.0 2.5	5.0 5.0 2.0 4.0	6.0 5.0 2.5 5.0
$\Delta_{CS}$ single bearing deviation of single width of the outer ring – width tolerance	P4 HG UP P2	Identical to $\Delta_{BS}$ for the inner ring of the same bearing				
$\Delta_{CS}$ matched bearing deviation of single width of the outer ring – width tolerance	P4 HG UP P2	Identical to $\Delta_{BS}$ for the inner ring of the same bearing				
$V_{CS \max}$ outer ring width variation – width variation	P4 HG UP P2	2.5 2.0 2.0 1.5	2.5 2.0 2.0 1.5	2.5 2.0 2.0 1.5	3.0 2.0 2.0 1.5	4.0 2.0 2.0 1.5

\* For bearings with shields (Z, 2Z)  $V_{Dp \max}$  is not restricted

## Contact angle $\alpha$

The contact angle is formed by a straight line drawn between the points of contact of the balls with the raceways and a plane perpendicular to the bearing axis. Externally applied loads are transmitted from one ring to the other along this line.

The contact angle depends on the radial clearance and the raceway curvature. A uniform load distribution within two or more bearings is given only when all bearings have identical contact angles. GMN provide such selected bearing pairs plus documentation on request. When using such bearings provision must be taken to ensure that both bearings have the same contact angle after mounting and adjustment to operating conditions.

The contact angle is designed into the bearing and changes during operation with speed, the external forces and the difference in temperature between the inner and outer ring.

With increasing contact angle

- Limiting speed decreases
- Radial rigidity decreases
- Axial rigidity increases

GMN manufacture spindle bearings with 15° and 25° contact angles. Other contact angles available on request.

## Internal Clearance

The internal clearance defines the amount by which one bearing ring can be displaced relative to the other without gauging load.

- Radial clearance: Displacement in radial direction
- Axial clearance: Displacement in axial direction

The internal clearance of a bearing is not a quality feature.

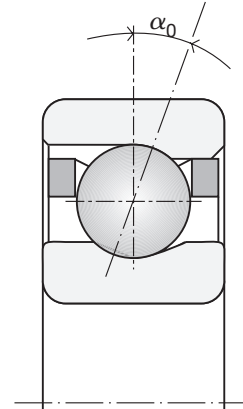

$\alpha_0$  = Nominal contact angle

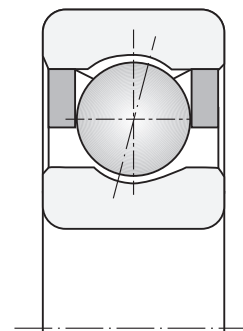

## Form and running accuracy

Low vibration level and high running accuracy are ensured by random sample production control on the rings and the balls. Form accuracy and surface finish are checked by using advanced precision measuring instruments, the runouts of assembled bearings are checked 100%.

## Vibration

The vibration level depends, among other things, on:

- Form accuracy and surface finish of raceways and balls
- Cage design
- Cleanliness and method of lubrication

A 100% vibration test is carried out with all GMN high precision ball bearings. The spectral analysis carried out regularly by taking random samples gives information on the inner and outer ring as well as ball form accuracy. The vibration spectrum of a ball bearing is essentially discreet, the dominating frequencies are design related. The specific frequencies of a bearing can be calculated with the aid of the formulae shown opposite.

Apart from highly advanced manufacturing machines constant production control ensures the uniform quality of GMN high precision ball bearings. Sophisticated measuring systems and quality assurance methods ensure a high degree of accuracy, low friction, a high degree of quiet running, highest speeds and a long service life.

Ball pass frequency  $f_{AR}$  on the outer ring

$$f_{AR} = \frac{Z}{2} \cdot f_i \cdot \left(1 - \frac{D_w}{T} \cos \alpha_0\right) [1/\text{sec}]$$

Ball pass frequency  $f_{iR}$  on the inner ring

$$f_{iR} = \frac{Z}{2} \cdot f_i \cdot \left(1 + \frac{D_w}{T} \cos \alpha_0\right) [1/\text{sec}]$$

Ball spin frequency  $f_w$

$$f_w = \frac{f_i}{2} \cdot \left(\frac{T}{D_w} - \frac{D_w}{T} \cos^2 \alpha_0\right) [1/\text{sec}]$$

Cage rotation frequency  $f_K$

$$f_K = \frac{f_i}{2} \cdot \left(1 - \frac{D_w}{T} \cos \alpha_0\right) [1/\text{sec}]$$

$f_i$  = Shaft frequency 1/sec

$D_w$  = Ball diameter in mm

$T$  = Pitch diameter in mm

$Z$  = Number of balls

$\alpha_0$  = Contact angle

## Radial runout

Meeting the radial runout of the inner and outer ring, specified in the various standards, is 100% controlled. On request the highest point (max wall thickness) is

## Matching accuracy

The matching accuracy of  $\pm 2$  microns for a single bearing ensures a uniform load distribution and a uniform operating temperature within the series. GMN offers bearing pairs with increased matching accuracy

## Grading

When two or more matched bearings carry a load together the bore and outside diameter should be identical. Due to the selective pairing of bore and outside diameter the fitting on the shaft and in the housing are facilitated. On special request GMN grades the tolerances of bore and outside diameter. The suffix here to is "X". Tolerances smaller than 3 microns are not graded. The grading groups can, for practical reasons, only be selected, but not manufactured separately.

The groups are marked on the box as follows:

marked by a point on the face. This is an additional help for the user to minimise wobble.

( $\pm 1$  micron) on request. When specifying the type of matching, like DB, DF or DT for pairs or groups matching takes place to an optimum for precision class HG and UP.

Grade	Bore	Outer diameter
X11	O	O
X12	O	U
X21	U	O
X22	U	U
X10	O	-
X20	U	-

O = Upper tolerance half

- = No grading

U = Lower tolerance half

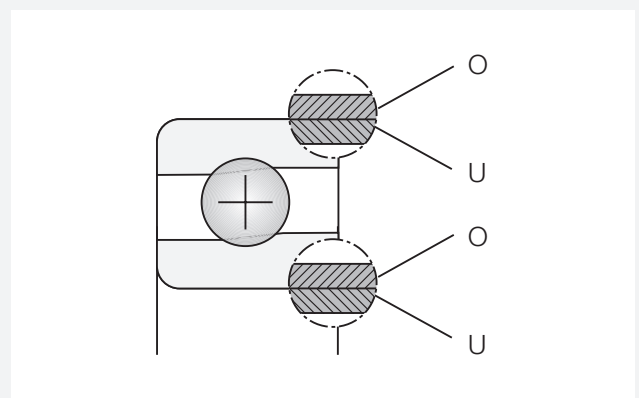

## Preload

The preload is defined as a permanent axial load applied to a bearing.

The advantages of a preload:

- High running accuracy and low vibration level of the bearing arrangement, as the internal clearance is eliminated.
- Reduction of deflection (diagram 1)
- Increase of rigidity of the bearing (diagram 2)
- Reduction of the sliding friction share at high speeds, as the change of the contact angle between inner and outer ring is reduced. A measure of the sliding friction share is the spin/roll ratio (diagram 3)
- Prevents ball skid during high acceleration
- Increases the load-carrying capacity of the bearing arrangement.

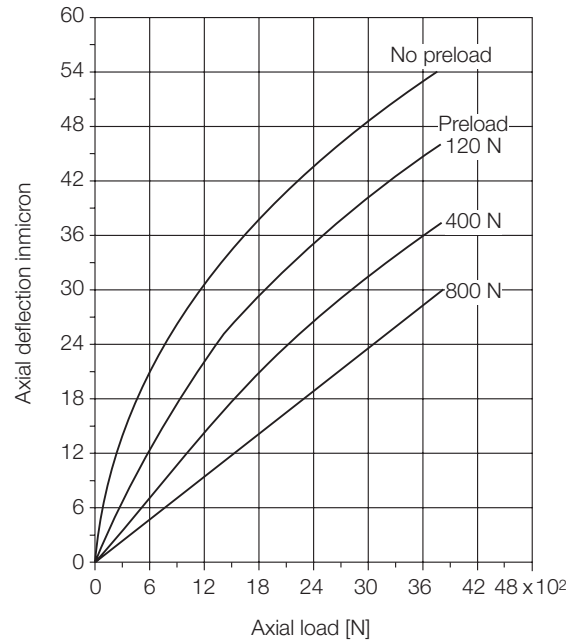

Diagram 1

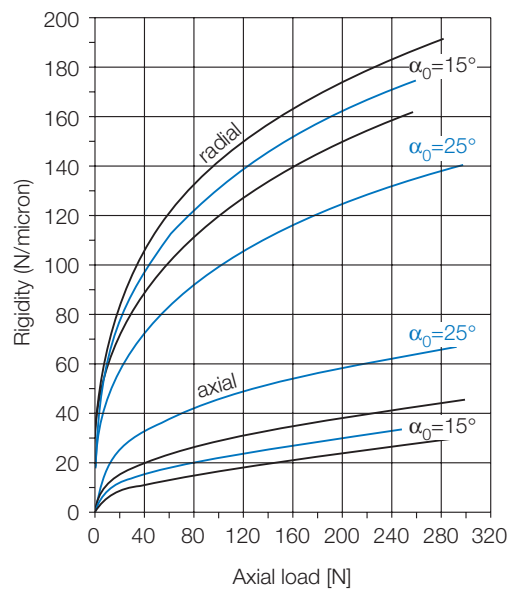

Diagram 2

## Rigidity

The rigidity is defined as the external load of a bearing, which causes a deflection of 1 micron of the bearing rings to each other.

The values for axial rigidity are shown in the bearing tables.

## Lift off force

The lift off force is the limit for the external axial load. Exceeding this value leads to removal of the preload. Condition is a mutual preloaded bearing set.

Consequences when external load exceeds lift off force:

- The balls and the raceways of the relieved bearing are no longer in permanent contact
- Wear rises as sliding friction increases

The values of the lift off force are shown in the bearing tables.

## Minimum preload at high speeds

A minimum preload at high speeds is indispensable to limit the sliding friction share.

Effect of insufficient minimum preload:

- The balls and raceways are no longer in permanent contact
- Wear rises as sliding friction increases
- Reduction of service life

The values for minimum preload are shown in the bearing tables.

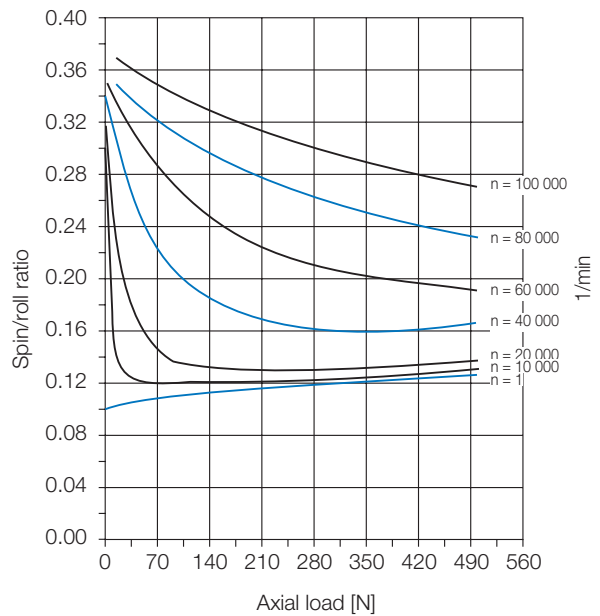

Diagram 3

## Types of preload

### Spring preload

Characteristics:

- Insensitive to different thermal expansion of shaft and housing
- Suitable for very high speeds

The drawing shows a spindle where bearing 1 has a fixed location, whereas the outer ring of bearing 2 is free to move axially. The spring force acts on the outer ring of bearing 2 and results in a permanent preload of both bearings almost independent of speed and temperature factors. Care must be taken to ensure **easy movement** of the adjusted outer ring. Bearings preloaded in this way can be used up to the limiting speed of single bearings if oil lubrication is used. The spring has to be arranged to be effective in the same direction as the external axial load.

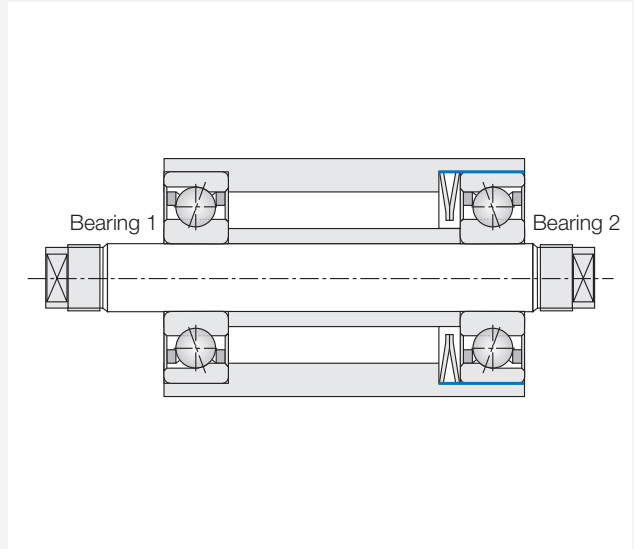

### Rigid preload

Characteristics:

- Higher rigidity at radial loads
- Lower limiting speed compared to spring preload
- The magnitude of preload changes due to length variations as a result of temperature differences between shaft and housing
- Distinct higher axial rigidity than with spring preload

With the spindle shown in the drawing both bearings are paired and mounted stationary in an axial direction. Bearings arranged like this have a defined axial preload. The sleeves shown in the diagram must be ground to the identical length in one setting. GMN delivers the required bearing pairs with the necessary preload. The change of the preload under operating conditions has to be considered.

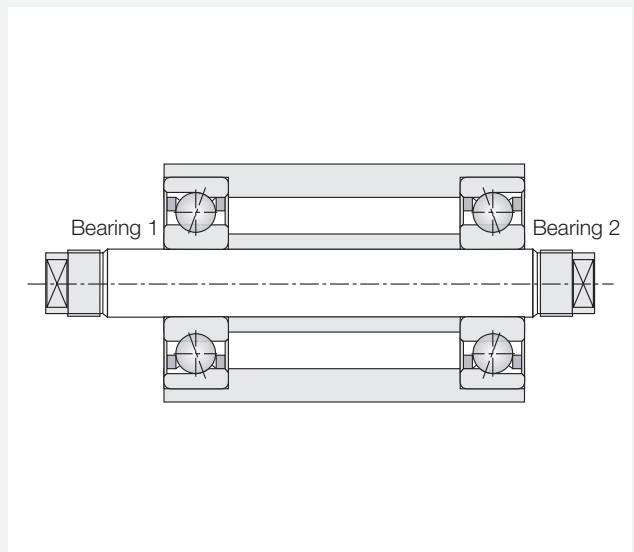

## Bearing arrangements

With the bearing arrangements listed below a large number of applications can be realised.

### DB arrangement

The contact lines diverge towards the bearing center line:

- Large spread  $H$  and thus a high rigidity to resist tilting moments
- Takes up axial loads in both directions

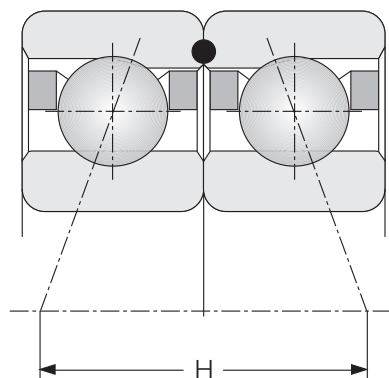

### DF arrangement

The contact lines converge towards the bearing center line:

- The spread  $H$  and the rigidity to resist tilting moments are smaller
- This arrangement is less sensitive to angular misalignment

As far as sustaining of loads and bearing deflection are concerned, the DF arrangement behaves like the DB arrangement.

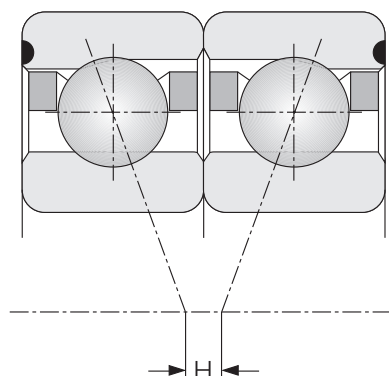



### DT arrangement

Two matched bearings are arranged in parallel in the direction of the load:

- Can be subjected to larger axial loads in one direction than a single bearing
- Both bearings must have the same contact angle and be adjusted against a third bearing

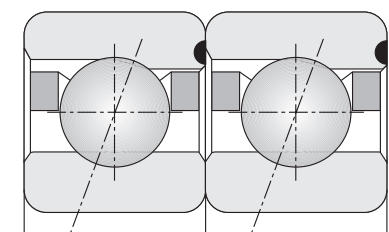
The preload is generally obtained by the use of springs.



Note:  Symbol in the diagram = face of the outer ring and indicates the bearing arrangement



## Multiple bearing arrangements

If a spindle is subjected to large loads or if a high degree of rigidity is required three or more bearings are used assembled in sets in DF, DB or DT arrangement. The drawings below show a few examples of multiple arrangements.

### Bearing sets with 2 bearings

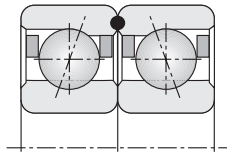

DB arrangement

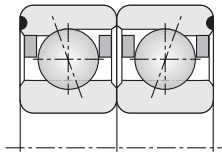

DF arrangement

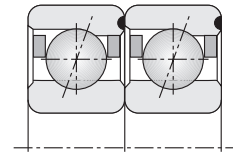

DT arrangement

### Bearing sets with 3 bearings

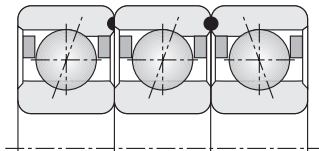

TBT

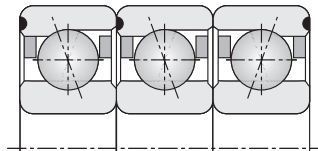

TFT

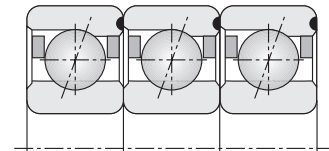

TDT

### Bearing sets with 4 bearings

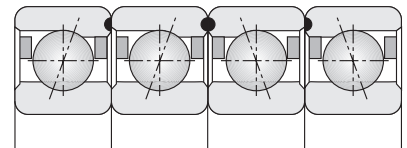

QBC

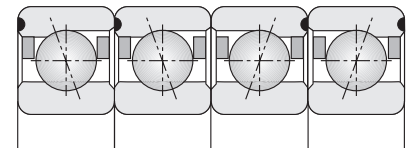

QFC

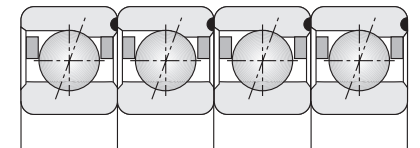

QTC

## Spacers

By fitting spacers with matched bearings the following is achieved:

- The spread H (with DF and DB arrangement) is increased
- Frictional heat is dissipated more effectively
- Lubrication of the bearing (oil lubrication) is improved as a result of better oil flow

The spacer width should correspond to at least the width of a single bearing.

Care must be taken to ensure good plane parallelism of spacers (see "accuracy of associated components"). Both spacers must be face ground in one setting.

A change of preload is possible with matched pairs of bearings by means of spacers.

If the spacer on the shaft is smaller than the spacer in the housing, then...

- Preload will be decreased with DF arrangement
- Preload will be increased with DB arrangement

The necessary dimensions for the spacers can be obtained on request.

## Universal matching

Matched bearings are universally ground as standard. All bearings of identical size and match can be mounted in pairs or sets in DF, DB or DT arrangements.

## Gauge matching

Bearings matched in this way come in pairs or sets and may not be mixed with bearings from a different box. The bearings within a set are numbered consecutively.

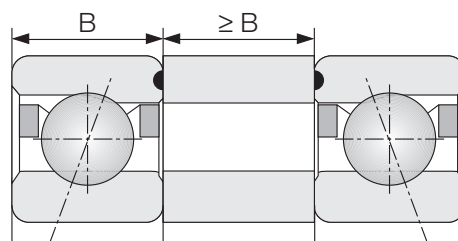

## Matched deep groove bearings

In many cases, bearing applications demand higher axial or radial capacity and smaller bearing dimensions or higher rigidity or a certain range of axial play. Such requirements can be met by matched bearings.

Only bearings from the same series and same dimension can be matched.

### 1. Universal matching

By universal matching single bearings can be assembled to DF, DB or DT configuration. Bearings with the same kind of matching (e.g. universal matching with same axial play, without axial play or with same preload) can be interchanged within their respective group.

When mounting universal matched bearings in the DT arrangement, with or without axial play or with preload the axial load is equally distributed.

Universal matched bearings from the same type of matching can be combined to form larger groups in the DF/DT arrangement or DB/DT arrangement with more than two bearings if required.

### Universal matching takes place with a measured load or a preload as shown in chart 2.1.

When mounting universal matched bearings the etching on the rings (type designation) must be noted according to the following illustrations.

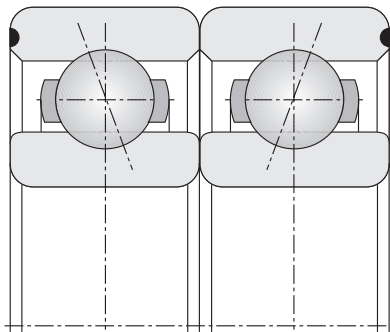

DF arrangement

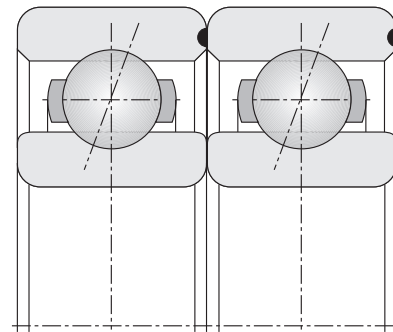

DT arrangement

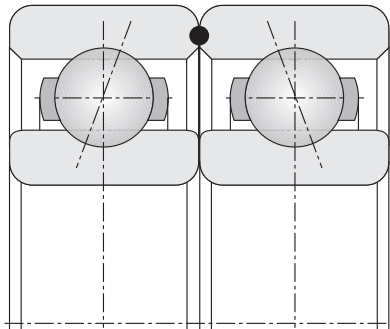

DB arrangement

Note:  Symbol in the diagram = face of the outer ring and indicates the bearing arrangement

## 1.1. Universal matching with axial play

### Symbol **DUA**

The bearings are prepared in such a way that with inner and outer rings locked together in the DF or DB arrangement, a certain axial play is included. As the magnitude of the axial play depends on the operating conditions, the axial play must be specified for each individual application. For example with axial play 40 to 60 microns, the symbol reads DUA 40.60.

## 1.2. Universal matching without axial play

### Symbol **DUO**

The bearings are prepared in such a way that with inner and outer rings locked together in DF or DB arrangement, there is no axial play in the bearing set.

## 1.3. Universal matching with preload

### Symbol **DUV**

When a rigid bearing arrangement, free from play, is required, a matching of bearings with preload is used. Bearings matched with preload have the advantage that under the effect of an external load only a small elastic deformation takes place, compared to unmatched bearing pairs or single bearings. The bearings are prepared in a way that with inner and outer rings locked together they are under the effect of a preload. The preload has to be considered as an additional axial load in the life time calculation.

The preload of DUV matched bearings is 2% of the dynamic load rating, however the max is 300N. A preload can be specified to suit your requirements.

## 2. Measuring loads and tolerances

### 2.1. Measuring loads and preloads

Type of matching	Measuring load	
DF DB DT DUA DUO	d	
	3 - 7 mm	12 N
	8 - 15 mm	22 N
	15 - 30 mm	32 N
	over 30 mm	50 N
DUV Preload meeting the individual application	2% of dynamic load rating however max 300N	

### 2.2. Width tolerance of matched deep groove bearings

Type of matching	Width tolerance [μm]	
DF DB DT	B	0 - 250
DUA DUO DUV	B <sub>1</sub>	0 - 500

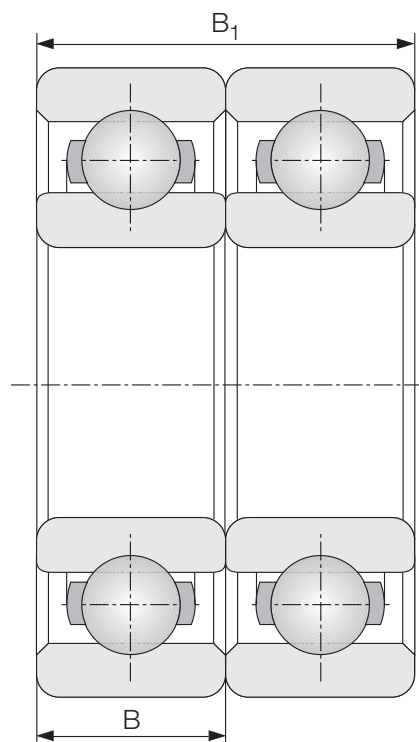

## Lubrication

The correct choice of lubricant and method of lubrication is as important for the proper operation of the bearing as the selection of the bearing and the design of the associated components.

### Grease lubrication

Grease should be used if ...

- Maintenance-free operation over long periods of time is desired
- The maximum speed of the bearing does not exceed the speed factor  $n \cdot d_{m}$  of the grease
- The heat generated is almost uniformly dissipated by the environment
- Low friction losses are required with bearings working under small loads and at high speeds

#### Running-in period with grease lubrication

In order to obtain an optimum lubrication effect and grease life it is advisable to provide for a running-in period for bearings for high-speed applications. A better grease distribution and, at the same time, a low bearing temperature are thus achieved.

When choosing the lubrication, GMN Application Support gladly supplies information about the lubricant, the quantity of grease and run-in procedures to apply it.

Grease manufacturers offer a multitude of greases suitable for high speeds. The  $n \cdot d_{m}$  factor is a criterion for the selection of the grease taking into consideration bearing size and operating speed.

$$n \cdot d_{m_{brg}} = \frac{n \cdot (D + d)}{2} \left[ \frac{\text{mm}}{\text{min}} \right]$$

D: Bearing outside diameter [mm]  
 d: Bearing bore diameter [mm]  
 n: Bearing operating speed [1/min]

The following table shows a selection of greases which can be used for high speeds (speed coefficient  $n \cdot d_{m} \geq 1 \cdot 10^6$  mm/min). Depending on the specific application, it is possible to attain speeds up to  $1.5 \cdot 10^6$  mm/min and higher with synthetic high speed greases.

GMN Code	Thickener	Base oil	Kinem. viscosity for base oil to DIN 515		Consistency DIN 51817 [NLG]	Temperature range to [°C]	$n \cdot d_{m}$ Factor [mm/min]	Comments on application
			approx. mm <sup>2</sup> /s 40 °C	100 °C				
274	Special-lithium	PAO/Ester	25	6.0	2/3	- 40 ... +140	$2.2 \cdot 10^6$	High speed grease. Very good wear protection. Very suitable for hybrid bearings with ceramic balls. Affords good corrosion protection.
249	Special-calcium	Ester + Mineral	23	4.7	2	- 40 ... +130	$1.3 \cdot 10^6$	Very good wear protection. Very low frictional moment. Highly suitable for hybrid bearings with ceramic balls. Affords good corrosion protection. Good resistance to water. Highly resistant to ageing.
007	Lithium-soap	Ester + Mineral	15	4.5	2	- 50 ... +120	$1.0 \cdot 10^6$	Low load. Very low frictional moments
122	Lithium-soap	Synthetic hydro-carbon	19	4.2	0	- 60 ... +130	$1.0 \cdot 10^6$	Special wear protection. Suitable for relatively high loads, low frictional moment.
005	Barium-complex	Ester + Mineral	23	4.7	2	- 30 ... +130	$1.0 \cdot 10^6$	Very good wear protection. Very low frictional moment. Highly suitable for hybrid bearings with ceramic balls. Affords good corrosion protection. Good resistance to water. Highly resistant to ageing.
126	Barium-complex	Synthetic hydro-carbon	30	5.5	2	- 50 ... +150	$1.0 \cdot 10^6$	Suitable for relatively high loads. Offers good corrosion protection. Very good resistance to water. Highly resistant to ageing.

## Oil lubrication

Oil lubrication should be provided if ...

- High speeds do not permit the use of greases
- The lubricant must simultaneously serve to cool the bearing

The most widely used lubricating methods are:

### • Oil mist lubrication

The oil mist is produced in an atomiser and conveyed to the bearings by an air current. The air current also serves to cool the bearings and the slightly higher pressure prevents contamination from penetration.

### • Oil-air lubrication (minimized lubrication)

The oil is conveyed to the bearing in droplets by compressed air. The droplet size and the intervals between two droplets are controlled.

### • Oil-jet lubrication (cooling lubrication)

Considerable amounts of oil are carried through the bearing by injection, the frictional heat generated in the bearing is dissipated. The cooling of the oil is achieved e.g. with an oil-to-air heat exchanger.

Frequently used oils are listed in the following table:

Oil grade	Setting-point approx. [°C]	Flash-point approx. [°C]	Kinematic viscosity for base oil [mm <sup>2</sup> /s]		Temperature range approx. [°C]	Specification	Remarks/Application
			40°C	100°C			
Mineral	-33	+120	32.0	5.4	-25 ... +80		Good corrosion and ageing resistance, oil-air lubrication
Mineral	-36	+98	3.1 at 20 °C	2.1 at 40 °C	–		Stable against oxidation, non-corrosive, oil injection lubrication
Ester	-70	+205	12	3.2	approx. -65 ... +100		Low-temperature and long-life oil, subjectionable to high pressure, oxidation stable with flat V/T diagram measuring technology, turbines, tape recorders
Alkoxy-fluor	-30	non-flam-able	190	22	-25 ... +220		Vacuum up to $1.33 \times 10^{-10}$ bar, radioactive radiation up to $5 \times 10^6$ J/kg resistance to aggressive chemicals and organic solvents
Synthetic	-60	+220	12.2	3.2	to +130	MIL-L-6085A AIR 3511A	Low degree of evaporation, particularly suitable for low temp., resistant to oxidation and corrosion/aircraft bearings, instr. bearings, wick-feed lubrication
Ester	-68	+220	14.3	3.7	-50 ... +120	MIL-L-6085A	Good resistance to ageing and corrosion, low degree of vaporization aircraft bearings, instrument bearings
Mineral	-51	+150	10	7.4 at 50 °C	-20 ... +80		Favourable viscosity/temperature relationship, high resistance to ageing grinding spindles, spindles in textile machines, oil-mist lubrication
Mineral	-50	>150	10	8.5 at 50 °C	-40 ... +80		Favourable viscosity/temperature relationship, high resistance to ageing grinding spindles, spindles in textile machines, oil-mist lubrication
Silikon	-65	+280	60	20	-55 ... +200		High- and low-temperature oil space industry, aircraft industry, tape recorders etc. only when $C/P > 40$ and speed characteristic $(n \cdot d_m) > 200\ 000$

## Accuracy of associated components

The machining quality and the correct selection of fits with regard to bearing seats are of great importance for the proper operation of a precise bearing application.

Standard **values for shaft and housing fits** for precision classes P4, HG, UP, P2 are listed in the following tables.

### Shaft (rotating)

Nominal diameter (mm)		Over Incl.	3 6	6 10	10 18	18 30	30 50	50 80
Shaft limits (micron)	P4	Upper Lower	-0 -5	-0 -5	-0 -6	-0 -7	-0 -8	-0 -9
	P2 HG UP	Upper Lower	-0 -4	-0 -4	-0 -5	-0 -6	-0 -7	-0 -8

### Housing

Nominal diameter (mm)			Over Incl.	10 18	18 30	30 50	50 80	80 120
Housing limits (micron)	P4	Locating bearing	Upper Lower	+ 8 + 0	+ 9 + 0	+ 10 + 0	+ 11 + 0	+ 12 + 0
	P4	Floating bearing	Upper Lower	+ 10 + 2	+ 11 + 2	+ 13 + 3	+ 14 + 4	+ 15 + 4
	P2 HG UP	Locating bearing	Upper Lower	+ 5 + 0	+ 6 + 0	+ 7 + 0	+ 8 + 0	+ 9 + 0
	P2 HG UP	Floating bearing	Upper Lower	+ 7 + 2	+ 8 + 2	+ 9 + 2	+ 10 + 2	+ 11 + 2



The running accuracy and low operating temperature of the bearing application depend on the machining quality with regard to abutment surfaces and bearing seats.

**Standard values for form and position tolerances** are listed in the following tables.

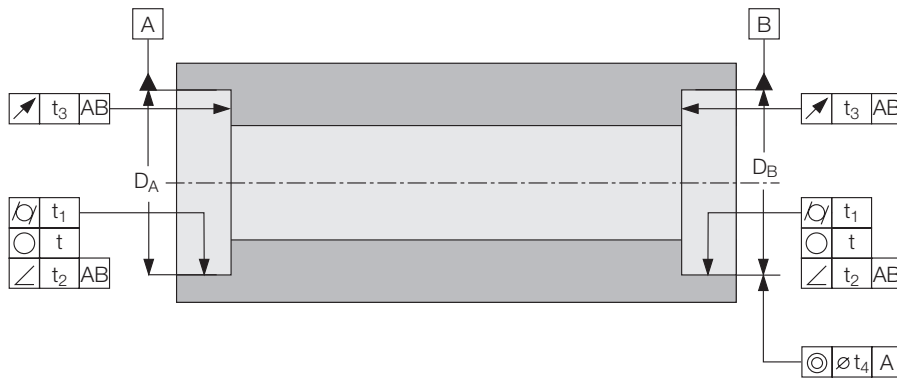
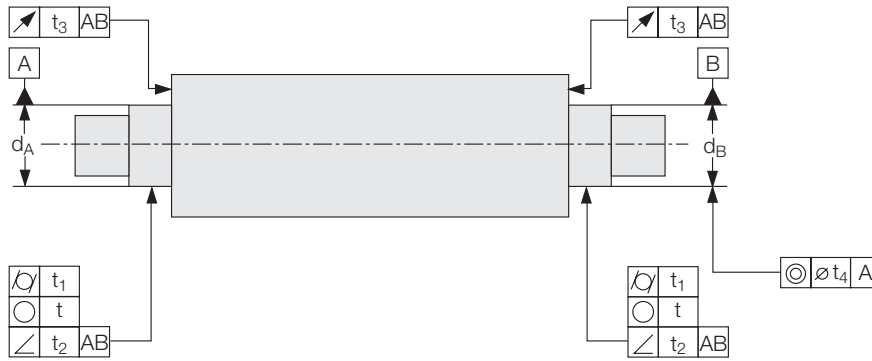

Property	Symbol for tolerance	Tolerance value	Permissible deviation of form for bearings of tolerance classes	
			P4 (HG)	P2 (UP)
Roundness	○	$t_1$	IT1	IT0
Conicity (Taper)	⊙	$t_1$	IT1	IT0
Angularity	∠	$t_2$	IT1	IT0
Axial runout	↗	$t_3$	IT1	IT0
Concentricity (Misalignment)	◎	$t_4$	IT3	IT3

Nominal diameter in (mm)	Tolerance quality in micron			
	IT0	IT1	IT2	IT3
> 6 - 10	0.6	1	1.5	2.5
> 10 - 18	0.8	1.2	2	3
> 18 - 30	1	1.5	2.5	4
> 30 - 50	1	1.5	2.5	4
> 50 - 80	1.2	2	3	5
> 80 - 120	1.5	2.5	4	6

## Bearing calculation

The method of calculation described as follows is an extract from DIN/ISO 76 (static load rating) and DIN/ISO 281 (dynamic load rating, life rating).

### 1. Definition of dynamic load rating C

for two or more spindle bearings in DF, DB or DT arrangement:

$$C = i^{0,7} \cdot C_{\text{single bearing}} \text{ [N]}$$

$i$  : Number of bearings in bearing set  
 $C_{\text{single bearing}}$  : Load rating of single bearing [N]

### 2. Definition of equivalent dynamic load P

$$P = X \cdot F_r + Y \cdot F_a \text{ [N]}$$

$X, Y$  : Radial factor, axial factor  
 $F_r, F_a$  : Radial load, axial load [N]

The preload of the bearing must be taken into consideration:

- If  $K_a \leq 3 \cdot F_v$  then use  $F_a = F_v + 0.67 \cdot K_a$  [N]
  - If  $K_a > 3 \cdot F_v$  then use  $F_a = K_a$  [N]
- $K_a$  : external axial load [N]  
 $F_v$  : Preload of a bearing set [N]

### 3. Definition of X and Y factors

	Relative in axial load $i \cdot F_a / C_0$ 1)	Single bearing DT arrangement 2)				Bearing pair DF or DB arrangement				
		e	$F_a / F_r \leq e$		$F_a / F_r > e$		$F_a / F_r \leq e$		$F_a / F_r > e$	
			X	Y	X	Y	X	Y	X	Y
Spindle bearing Contact angle 15 °	0.015	0.38				1.47		1.65		2.39
	0.029	0.40				1.40		1.57		2.28
	0.058	0.43				1.30		1.46		2.11
	0.087	0.46				1.23		1.38		2.00
	0.120	0.47	1	0	0.44	1.19	1	1.34	0.72	1.93
	0.170	0.50				1.12		1.26		1.82
	0.290	0.55				1.02		1.14		1.66
	0.440	0.56				1.00		1.12		1.63
	0.580	0.56				1.00		1.12		1.63
Spindle bearing Contact angle 25 °		0.68	1	0	0.41	0.87	1	0.92	0.67	1.41
Deep groove bearing Standard radial play	0.014	0.23				2.30		2.78		3.74
	0.028	0.26				1.99		2.40		3.23
	0.056	0.30				1.71		2.07		2.78
	0.085	0.34				1.55		1.87		2.52
	0.110	0.36	1	0	0.56	1.45	1	1.75	0.78	2.36
	0.170	0.40				1.31		1.58		2.13
	0.280	0.45				1.15		1.39		1.87
	0.420	0.50				1.04		1.26		1.69
	0.560	0.52				1.00		1.21		1.63
Deep groove bearing radial play C3	0.014	0.29				1.88		2.18		3.06
	0.029	0.32				1.71		1.98		2.78
	0.057	0.36				1.52		1.76		2.47
	0.086	0.38				1.41		1.63		2.29
	0.110	0.40	1	0	0.46	1.34	1	1.55	0.75	2.18
	0.170	0.44				1.23		1.42		2.00
	0.290	0.49				1.10		1.27		1.79
	0.430	0.54				1.01		1.17		1.64
	0.570	0.54				1.00		1.16		1.63

1)  $C_0$ : Static load rating (N)

2) For DT arrangement set  $i=1$  and use  $F_a$  and  $C_0$  values related to single bearing

## 4. Definition of nominal life rating $L_{10h}$

$$L_{10h} = \frac{10^6}{60 \cdot n} \cdot \left(\frac{C}{P}\right)^3 \text{ [hours]}$$

$n$  : Speed (1/min)

$C$  : Dynamic load rating [N]

$P$  : Equivalent dynamic load [N]

The nominal life rating is based on a 10% probability of failure.

## 5. Definition of adjusted life rating $L_{nah}$

$$L_{nah} = a_1 \cdot a_{23} \cdot f_t \cdot L_{10h} \text{ [hours]}$$

$a_1$  : Factor for probability of failure

$a_{23}$  : Factor for material and operating conditions

$f_t$  : Factor for operating temperature

$L_{10h}$  : Nominal life rating [hours]

Probability of failure [%]	10	5	4	3	2	1
Factor $a_1$	1	0.62	0.53	0.44	0.33	0.21

Maximum operating temperature (°C)	150	200	250	300
Factor $f_t$	1	0.73	0.42	0.22

## 6. Definition of factor for material and operating conditions $a_{23}$

Step 1:

The operating viscosity  $\nu$  is determined in diagram 1. For grease lubrication, the viscosity of the base oil is entered.

Step 2:

The reference viscosity  $\nu_1$  is determined in diagram 2.

Step 3:

After calculation of the viscosity ratio  $\nu/\nu_1$ , the  $a_{23}$ -factor is determined in diagram 3.

Comments on diagram 3:

- Lower line: Normal operating conditions and cleanliness.
- Middle line: Improvement of  $a_{23}$ -factor by EP-additives.
- Upper line: Improvement of  $a_{23}$ -factor by extreme (highest) cleanliness and optimised spin and slide conditions.

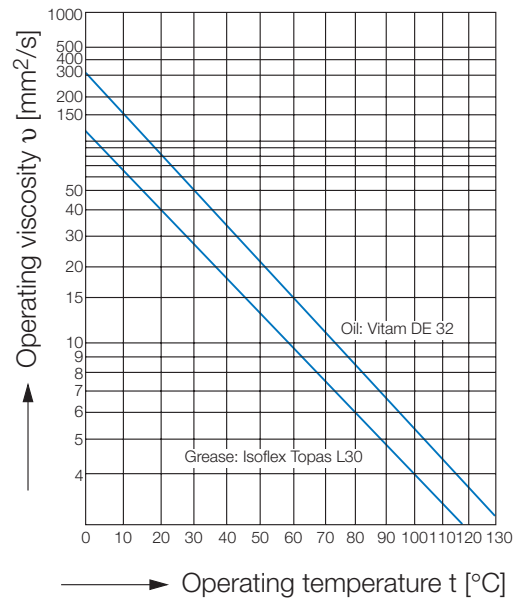

Diagram 1

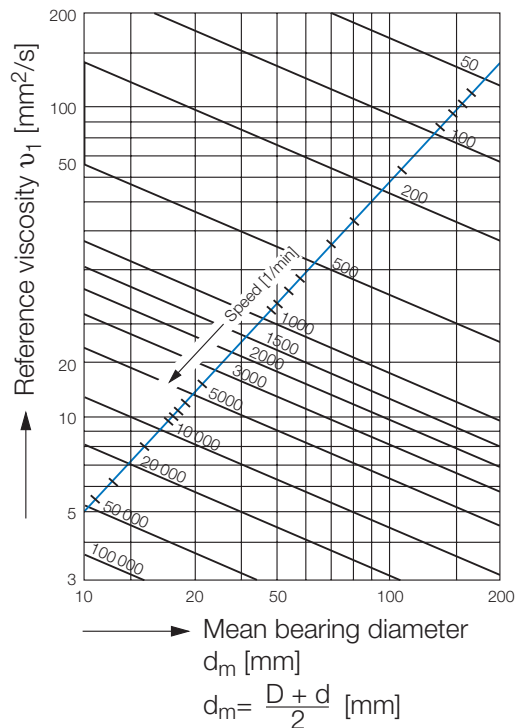

Diagram 2

With the adjusted life time rating it is possible to take into account various influencing parameters:

- Probabilities of failure, deviating from 10% ( $a_1$ -factor)
- Material properties ( $a_2$ -factor): GMN uses steel with a particularly high degree of purity, therefore:  $a_2 = 1$
- Lubricant film thickness, lubricant additives, contamination ( $a_3$ -factor)
- Deviation from normal operating temperature ( $> 150\text{ °C}$ ) ( $f_t$ -factor)

Apart from the fatigue life (theoretical life rating) the actual service life of a bearing is determined also by wearlife rating and the service life of the grease.

The current **GLOBUS** ball bearing calculation program can be downloaded from the GMN internet portal, [www.gmn.de](http://www.gmn.de). Furthermore, the program can calculate bearing-specific frequencies and has an extendable lubrication database.

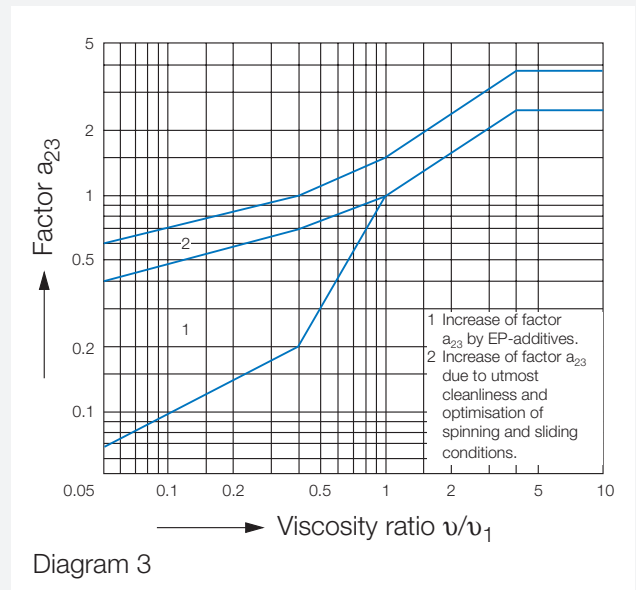

## Definition of static load rating $C_0$

### 1. Definition of static equivalent load $P_0$

$$P_0 = X_0 \cdot F_r + Y_0 \cdot F_a$$

if  $P_0 < F_r$ , then use  $P_0 = F_r$

$X_0, Y_0$ : Radial factor, axial factor: see table  
 $F_r, F_a$ : Radial load, axial load [N]

	Single bearing DT arrangement		Bearing pair in DF or DB arrangement	
	$X_0$	$Y_0$	$X_0$	$Y_0$
Contact angle 15°	0.5	0.46	1	0.92
Contact angle 25°	0.5	0.38	1	0.76
Deep groove bearing	0.6	0.5		

### 2. Definition of static coefficient $f_s$

$$f_s = i \cdot C_0 / P_0$$

$i$  : number of bearings  
 $C_0$  : Static load rating (N)  
 $P_0$  : Static equivalent load (N)

- The value of the static coefficient should be above 2.5
- The static coefficient describes the safety against excessive plastic deformation of the points of contact of balls and raceways.

## Service life of grease – Lubrication intervals

The lubricating interval is defined on principle as the value for a 10 to 20% probability of failure of the service life of the grease.

The service life of the grease is essentially dependent on the influencing parameters

- Grease
- Operating conditions
- Design

Therefore, the selection of the grease is of decisive importance. In the opposite graph 1 (reproduced from the Recommendations 2.4.1 of the Society of Tribology), **the lubricating interval  $t_f$**  is plotted against the operating speed and the limiting speed of grease lubrication. It provides guiding values for the service life and applies to lithium soap grease up to an operating temperature of +70 °C (measured on the outer ring) and moderate conditions of loading ( $P/C < 0.1$ ).

**Special environmental factors**, such as humidity and vibration will decrease the lubricating interval to 1/5 of the initial value.

### Unusual conditions of operation

e.g. extreme temperatures and high loading ( $P/C > 0.1$ ) call for special greases. These greases will enable longer lubricating intervals to be achieved than those obtained from the graph.

Lubricating intervals of more than 5 years are possible only under very favourable environmental conditions.

### Reduction in lubricating intervals at high temperatures

The degradation of the lubricating greases increases considerably at higher temperatures. A temperature increase by 15 K, starting at 70 °C, will decrease the lubricating interval to half the initial value, particularly with lithium greases. Guidance is provided by the graph 2.

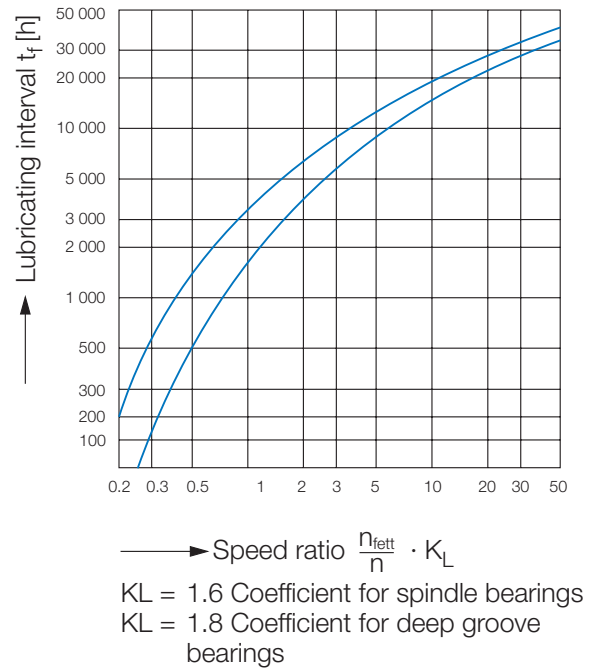

Graph 1

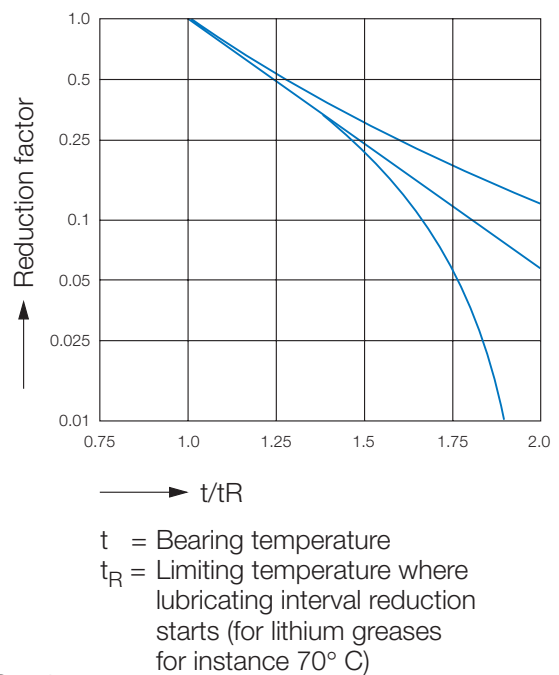

Graph 2

The stable operation condition of a bearing is endangered as soon as the limiting speed is attained or exceeded. Within the range of the contacting areas between the balls and the rings friction and temperature increase progressively.

The friction generated in the bearing depends essentially on:

- Speed
- Bearing load
- Viscosity of the lubricant
- Amount of lubricant

## Limiting speed for spindle bearings

The speeds listed in the tables are attainable speeds for a single spring-preloaded bearing operating under normal conditions such as









- Good heat dissipation
- Low external load
- Rotating inner ring
- Oil-mist or oil-air lubrication
- Good form accuracy of associated components
- Alignment of associated components

If the operating conditions deviate from the conditions mentioned these must be taken into account by correction factors.

Correction factors and speed values are only for guidance.

$$\text{Permissible speed} = \text{speed value} \cdot f_{n1} \cdot f_{n2} \cdot f_{n3} \cdot f_{n4}$$

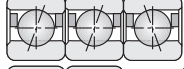
## Correction factors

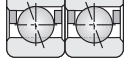
f <sub>n1</sub> : Lubrication			Preload				
			L	M	S		
Grease lubrication (note n · dm factor of grease) Oil-air or oil-mist lubrication		0.75					
		1.0					
f <sub>n2</sub> : Bearing arrangement bearing pairs	Single bearing with spring preload	 	1.0				
	Rigid			0,8	0,7	0,5	
					0,75	0,6	0,4
					0,7	0,6	0,4
					0,6	0,5	0,3
					0,65	0,5	0,3
f <sub>n3</sub> : Kinematics	Rotating inner ring Rotating outer ring	1.0 0.6					
f <sub>n4</sub> : Ball material	Steel Ceramic Si <sub>3</sub> N <sub>4</sub>	1.0 1.25					

## Limiting speed for deep groove bearings

The speeds listed in the tables are attainable speeds for a single spring-preloaded bearing operating under normal conditions such as

- Good heat dissipation
- Low external load
- Rotating inner ring
- Grease lubrication
- Good form accuracy
- Good balancing of rotating parts

If the operating conditions deviate from the conditions mentioned these must be taken into account by correction factors.

Correction factors and speed values are only for guidance.

$$\text{Permissible speed} = \text{Speed value} \cdot f_{n1} \cdot f_{n2} \cdot f_{n3} \cdot f_{n4} \cdot f_{n5}$$

## Correction factors

$f_{n1}$ : Lubrication	Grease lubrication (note n · dm factor of grease) Oil-mist lubrication	1.0 1.25
$f_{n2}$ : Cages	Y/J (n · dm < 625 000) T9H (n · dm < 1 400 000) TBH (n · dm < 1 000 000) TA (n · dm < 1 600 000) MA (n · dm < 1 350 000) TB (n · dm < 1 400 000) MB (n · dm < 1 200 000)	1.0 1.6 1.2 1.8 1.5 1.6 1.4
$f_{n3}$ : Kinematics	Rotating inner ring Rotating outer ring	1.0 0.6
$f_{n4}$ : Bearing arrangement bearing pairs	Single bearing with spring preloading Pairs in DF, DB, DT, DUA, DUO, DUJ	1.0 0.8
$f_{n5}$ : Ball material	Steel Ceramic (Si <sub>3</sub> N <sub>4</sub> )	1.0 1.25

## Radial clearance as per DIN 620/Part 4

Nominal bore size		Radial clearance in micron							
d mm		C2		CN		C3		C4	
over	to	min	max	min	max	min	max	min	max
1.5	6	0	7	2	13	8	23	–	–
6	10	0	7	2	13	8	23	14	29
10	18	0	9	3	18	11	25	18	33
18	24	0	10	5	20	13	28	20	36
24	30	1	11	5	20	13	28	23	41
30	40	1	11	6	20	15	33	28	46

## Basic rules for storage and assembly

- Store bearings in the original box
- Protect bearings against moisture
- Grease lubricated bearings: with proper storage approximately one year possible
- Check conditions of associated components
- Clean work place and suitable tools
- In general no rinsing of bearings
- For grease lubrication: Specify amount of grease (standard value 30% of void space, check with GMN) and equally grease the bearing in the ball/raceway area.
- No cocking of bearing during mounting. Heat bearing inner ring to max 100°C.



## Failure analysis

GMN provides a service to analyse damage to GMN bearings.

For this purpose please note:

- Send bearings to GMN without cleaning them
- Mark mounting position (fixed / floating bearing, direction of load etc.)
- Describe operating conditions





- HY**    **S**    **6002**    **X-2Z**    **C**    **TA**    **P4**    **R**    **X**    **D**    **UL**    **S1**    **Grease**  
 ①    ②    ③    ④    ⑤    ⑥    ⑦    ⑧    ⑨    ⑩    ⑪    ⑫    ⑬

① — Material	— Bearings made from chrome steel have no prefix <b>M</b> Bearings made from high temperature steel* <b>N</b> Bearings made from HNS-Steel* <b>HY</b> Balls and rings from different materials (Hybrid bearings)
② — Bearing type	<b>S</b> Two lands on the inner ring <b>SN</b> Two lands on the outer ring, for grease lubrication <b>SM</b> Two lands on the inner ring, for high speed applications <b>SMA</b> Two lands on the inner ring, for high speeds, but with lubricant supply through the outer ring <b>SMI</b> Two lands on the inner ring, for high speeds, but with lubricant supply through the inner ring <b>SH</b> One land on the inner ring and the outer ring, optimum for oil-jet lubrication <b>KH</b> One land on the inner ring and the outer ring, for high speed applications <b>BNT</b> Two lands on the outer ring, inner ring removable <b>BHT</b> Two lands on the outer ring, inner ring removable, for high speed applications
③ — Bearing size	<b>6002</b> Designation of dimension series and bore
④ — Special dimensions Seals	<b>X-2Z</b> Extra wide, shields with snap rings on both sides of the bearing* <b>2RZ</b> Seals on both sides (for KH series)
⑤ — Contact angle	<b>C</b> 15° <b>E</b> 25° <b>18°</b> Special feature*
⑥ — Cage	<b>TA</b> Laminated phenolic resin cage guided on outer ring <b>TB</b> Laminated phenolic resin cage guided on inner ring* <b>TAM</b> Laminated phenolic resin cage guided on outer ring, ball retaining <b>TXM</b> Molded plastic cage guided on outer ring, ball retaining
⑦ — Precision	<b>P4</b> Is equivalent to P4S according to DIN 628-6 <b>P2</b> Tolerance class P2 according to DIN 620 <b>A 7</b> Tolerance class ABEC 7 according to ABMA <b>A 9</b> Tolerance class ABEC 9 according to ABMA <b>HG</b> GMN high precision according to GMN specification <b>UP</b> GMN ultra precision according to GMN specification
⑧ — High pointing	<b>R</b> Indication of the point of radial runout (maximum wall thickness) on inner and outer ring <b>R<sub>i</sub></b> Like R, however only on the inner ring <b>R<sub>a</sub></b> Like R, however only on the outer ring
⑨ — Grading	<b>X</b> Grading of bore and outer diameter
⑩ — Bearing sets	<b>D</b> 2 bearings <b>T</b> 3 bearings <b>Q</b> 4 bearings
⑪ — Matching	<b>UL</b> Universal matching - light preload <b>UM</b> Universal matching - medium preload <b>US</b> Universal matching - heavy preload <b>UV</b> Universal matching - preload by agreement <b>F</b> Face-to-Face arrangement <b>B</b> Back-to-Back arrangement <b>T</b> Tandem arrangement
⑫ — Heat treatment	<b>S1</b> Operating temperature up to 200 °C * <b>S2</b> Operating temperature up to 250 °C * <b>S3</b> Operating temperature up to 300 °C *
⑬ — Lubrication	Designation of grease, e.g. <b>Turmogrease HS L252</b>

\* available on request.

In this table similar types of bearings are listed according to bearing design. The designations given contain only

the basic types, not exact details such as precision, matching, preload etc.

GMN	BARDEN	FAFNIR	FAG	RHP	SKF	SNFA	SNR
S 61800 CTA ⋮ S 61814 CTA						SEA 10 CE1 SEA 70 CE1	
S 61800 ETA ⋮ S 61814 ETA						SEA 10 CE3 SEA 70 CE3	
S 61900 CTA ⋮ S 61914 CTA		2 MM 9300 WO-CR  2 MM 9314 WO-CR	B 71900 C.T.  B 71908 C.T.	7900 X2TA  7908 X2TA	71900 CD  71914 CD	EB 10 CE1 SEB 17 CE1 SEB 70 CE1	71900 C  71908 C
S 61900 ETA ⋮ S 61914 ETA			B 71900 E.T.  B 71914 E.T.		71900 ACD  71914 ACD	EB 10 CE3 SEB 17 CE3 SEB 70 CE3	71900 H  71914 H
KH 61900 2RZ ⋮ KH 61914 2RZ		2 MM 9300 HX VV  2 MM 9314 HX VV	HSS 71900  HSS 71914		S 71900 B  S 71914 B	HB 10/S HB 70/S	MLE 71900 MLE 71914
S 6000 CTA ⋮ S 6014 CTA	100 H  114 H	2 MM 9100 WI  2 MM 9114 WI	B 7000 C.T. B 7014 C.T.	7000 X2TA 7014 X2TA	7000 CD 7014 CD	EX 10 CE1 EX 70 CE1	
SM 6000 CTA ⋮ SM 6014 CTA		2 MM 9100 WO-CR 2 MM 9114 WO-CR				VX 10 VX 50	
SM 6000 CTA ⋮ SM 6014 CTA						VEX (VEB) 10 VEX (VEB) 50	
KH 6000 2RZ ⋮ KH 6014 2RZ		2 MM 9100 HX VV 2 MM 9114 HX VV	HSS 7000 HSS 7014		S 7000 B S 7014 B	HX 10/S HX 70/S	MLE 7000 MLE 7014
BHT 6000 CTAM ⋮ BHT 6006 CTAM	100 B  106 B					ED 10 CE1 ED 30 CE1	
S 6000 CTB ⋮ S 6006 CTB				7000 X2T 7006 X2T			7000 C 7006 C
S 6000 ETA ⋮ S 6014 ETA	2100 H  2114 H	3 MM 9100 WI 3 MM 9114 WI	B 7000 E.T. B 7014 E.T.	7000 X3TA 7014 X3TA	7000 ACD 7014 ACD	EX 10 CE3 EX 70 CE3	7000 H 7014 H
S 6200 CTA ⋮ S 6213 CTA	200 H  213 H	2 MM 200 WI 2 MM 213 WI	B 7200 C.T. B 7213 C.T.	7200 X2TA 7213 X2TA	7200 CD 7214 CD	E 210 CE1 E 265 CE1	
S 6200 CTB ⋮ S 6206 CTB				7200 X2T 7206 X2T			7200 C 7206 C
S 6200 ETA ⋮ S 6213 ETA	2200 H  2214 H	3 MM 200 WI 3 MM 214 WI	B 7200 E.T. B 7213 E.T.	7200 X3TA 7213 X3TA	7200 ACD 7213 ACD	E210 CE3 E 270 CE3	7200 H 7213 H

## Spindle bearings

The following notations are used in the bearing tables:

d	[mm]	Bore diameter
D	[mm]	Outer diameter
B	[mm]	Width single bearing
$r_{smin}$	[mm]	Chamfer
$r'_{smin}$	[mm]	Chamfer open side (spindle bearing)
a	[mm]	Width of ring groove for SMI-lubrication
$D_w$	[mm]	Ball diameter
Z	pieces	Ball complement
m	[kg]	Weight of bearing
$d_1$	[mm]	Outer diameter inner ring
$d_2$	[mm]	Land inner ring, open side
$d_k$	[mm]	Cage bore
$d_m$	[mm]	Pitch circle diameter
$D_1$	[mm]	Bore outer ring
$D_2$	[mm]	Bore outer ring (open side)
n	[1/min]	Speed value
C	[N]	Dynamic load rating
$C_0$	[N]	Static load rating
$F_v$	[N]	Preload
$F_{amax}$	[N]	Lift off force
$C_{ax}$	[N/micron]	Axial rigidity (pair)
$F_f$	[N]	Minimum spring preload
$\alpha_0$	[°]	Contact angle

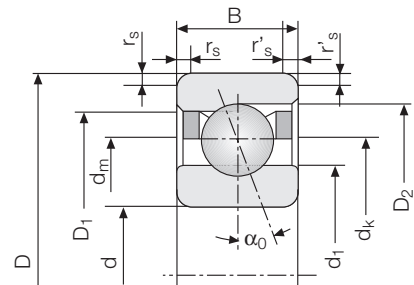

S618...; S619...; S60...; S62...

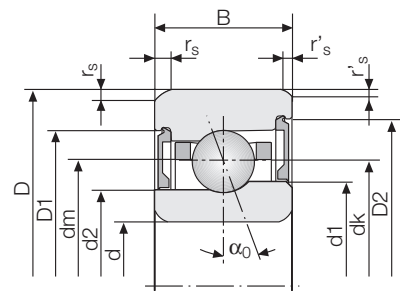

KH...

SMI 60...

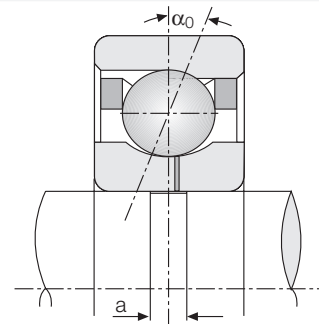

Minimum depth of ring groove 0.5 mm

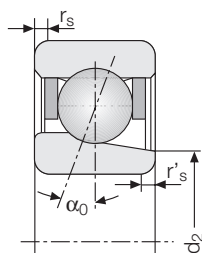

BHT60...; BNT62...

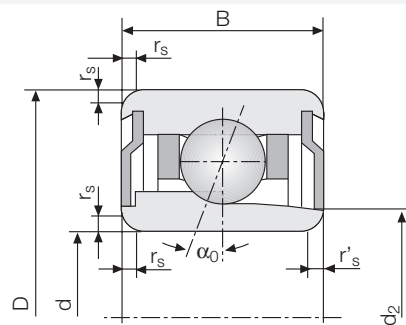

BHT...X

Boundary dimensions			Ball		Chamfer		Dimensions							Weight	Designation
d	D	B	D <sub>w</sub>	Z	r <sub>s_min</sub>	r' <sub>s_min</sub>	d <sub>1</sub>	d <sub>2</sub>	d <sub>k</sub>	d <sub>m</sub>	D <sub>1</sub>	D <sub>2</sub>	a	m	
5	11	3	1.588	10	0.15	0.15	6.65	-	7.70	8.00	8.95	9.40	-	0.001	<b>S 618/5 C TA</b>
5	13	4	2.381	8	0.20	0.20	7.10	-	9.00	9.00	10.70	11.30	-	0.002	<b>S 619/5 C TA</b>
5	14	5	2.381	8	0.20	0.20	6.90	-	8.70	9.50	10.30	11.00	-	0.004	<b>S 605 C TA</b>
5	14	5	2.381	8	0.20	0.20	6.90	-	8.70	9.50	10.30	11.00	-	0.004	<b>SM 605 C TA</b>
5	16	5	3.175	7	0.30	0.30	7.65	-	10.30	10.50	12.50	13.20	-	0.005	<b>S 625 C TA</b>
5	16	5	3.175	7	0.30	0.30	7.65	6.9	8.70	10.50	12.50	-	-	0.005	<b>BNT 625 C TAM</b>
6	13	3.5	1.588	12	0.15	0.15	8.35	-	9.35	9.50	10.65	11.10	-	0.002	<b>S 618/6 C TA</b>
6	15	5	2.381	9	0.20	0.20	8.50	-	10.35	10.50	12.10	12.70	-	0.004	<b>S 619/6 C TA</b>
6	17	6	2.381	9	0.30	0.30	8.30	-	10.10	11.50	11.70	12.40	-	0.005	<b>S 606 C TA</b>
6	17	6	2.381	9	0.30	0.30	8.30	-	10.10	11.50	11.70	12.40	-	0.005	<b>SM 606 C TA</b>
6	19	6	3.175	10	0.30	0.30	10.70	-	13.50	12.50	15.80	16.50	-	0.008	<b>S 626 C TA</b>
6	19	6	3.175	9	0.30	0.30	10.70	10.2	12.00	12.50	15.80	-	-	0.008	<b>BNT 626 C TAM</b>
7	14	3.5	1.588	13	0.15	0.15	9.35	-	10.35	10.50	11.65	12.10	-	0.002	<b>S 618/7 C TA</b>
7	17	5	2.381	11	0.30	0.30	10.00	-	11.80	12.00	13.60	14.10	-	0.005	<b>S 619/7 C TA</b>
7	19	6	3.175	10	0.30	0.30	10.70	-	13.50	13.00	15.80	16.50	-	0.007	<b>S 607 C TA</b>
7	19	6	3.175	10	0.30	0.30	10.70	-	13.50	13.00	15.80	16.50	-	0.007	<b>SM 607 C TA</b>
7	19	6	3.175	10	0.30	0.30	10.70	10.6	13.50	13.00	15.80	16.50	-	0.007	<b>SH 607 C TA</b>
7	19	6	3.175	9	0.30	0.30	10.70	10.2	12.00	13.00	15.80	-	-	0.007	<b>BHT 607 C TAM</b>
7	22	7	3.969	9	0.30	0.30	11.80	-	15.00	14.50	17.60	18.60	-	0.013	<b>S 627 C TA</b>
7	22	7	3.969	8	0.30	0.30	11.80	10.8	13.10	14.50	17.60	-	-	0.013	<b>BNT 627 C TAM</b>
8	16	4	1.984	12	0.20	0.20	10.60	-	11.90	12.00	13.40	14.00	-	0.003	<b>S 618/8 C TA</b>
8	19	6	3.175	10	0.30	0.30	10.70	-	13.65	13.50	15.90	16.50	-	0.007	<b>S 619/8 C TA</b>
8	22	7	3.969	9	0.30	0.30	11.80	-	15.00	15.00	17.60	18.60	-	0.010	<b>S 608 C TA</b>
8	22	7	3.969	9	0.30	0.30	11.80	-	15.00	15.00	17.60	18.60	-	0.010	<b>SM 608 C TA</b>
8	22	7	3.969	9	0.30	0.30	11.80	11.2	15.00	15.00	17.60	18.60	-	0.010	<b>SH 608 C TA</b>
8	22	7	3.969	8	0.30	0.30	11.80	10.8	13.10	15.00	17.60	-	-	0.012	<b>BHT 608 C TAM</b>
8	22	10.312	3.969	8	0.30	0.30	10.50	-	-	15.00	19.00	-	-	0.014	<b>BHT 608 X - 2Z</b>
9	17	4	1.984	13	0.20	0.20	11.60	-	12.90	13.00	14.40	15.00	-	0.003	<b>S 618/9 C TA</b>
9	20	6	3.175	11	0.30	0.20	12.40	-	14.90	14.50	17.20	17.90	-	0.007	<b>S 619/9 C TA</b>
9	24	7	3.969	10	0.30	0.30	13.45	-	16.90	16.50	19.90	20.60	-	0.014	<b>S 609 C TA</b>
9	24	7	3.969	10	0.30	0.30	13.45	-	16.90	16.50	19.90	20.60	-	0.014	<b>SM 609 C TA</b>
9	24	7	3.969	10	0.30	0.30	13.45	13.2	16.90	16.50	19.90	20.60	-	0.014	<b>SH 609 C TA</b>
9	24	7	3.969	9	0.30	0.30	13.45	12.7	15.30	16.50	19.90	-	-	0.014	<b>BHT 609 C TAM</b>
9	26	8	4.762	10	0.30	0.30	14.65	-	18.40	17.50	21.40	22.70	-	0.020	<b>S 629 C TA</b>
9	26	8	4.762	9	0.30	0.30	14.65	13.3	16.20	17.50	21.40	-	-	0.020	<b>BNT 629 C TAM</b>

Contact angle	Load rating		Speed value	Light preload			Medium preload			Heavy preload			Spring preload	Designation
	$\alpha_0$	C		$C_0$	n	$F_v$	$F_{a_{max}}$	$C_{ax}$	$F_v$	$F_{a_{max}}$	$C_{ax}$	$F_v$		
15	715	270	220000	3	9	6	11	37	10	21	76	13	20	<b>S 618/5 C TA</b>
15	1200	410	190000	6	19	7	18	61	11	36	130	15	30	<b>S 619/5 C TA</b>
15	1450	480	195000	7	22	8	20	70	13	40	150	20	40	<b>S 605 C TA</b>
15	1000	330	230000	5	15	5	14	45	9	28	96	13	33	<b>SM 605 C TA</b>
15	1950	750	170000	10	32	9	30	105	14	60	225	21	50	<b>S 625 C TA</b>
15	1750	640	150000	10	32	9	25	86	13	50	184	19	40	<b>BNT 625 C TAM</b>
15	790	330	180000	4	12	7	12	40	11	24	87	15	20	<b>S 618/6 C TA</b>
15	1300	470	165000	7	22	8	20	67	12	40	144	17	35	<b>S 619/6 C TA</b>
15	1550	560	170000	8	25	9	25	90	16	45	170	22	45	<b>S 606 C TA</b>
15	1100	380	200000	6	18	7	18	59	11	32	111	15	35	<b>SM 606 C TA</b>
15	2650	1150	125000	15	48	13	40	138	20	80	298	29	60	<b>S 626 C TA</b>
15	2400	1000	110000	12	38	11	35	121	18	70	260	25	50	<b>BNT 626 C TAM</b>
15	830	365	160000	4	12	7	12	40	12	25	90	16	20	<b>S 618/7 C TA</b>
15	1500	590	145000	8	25	9	23	77	15	46	164	21	40	<b>S 619/7 C TA</b>
15	2650	1150	125000	12	37	11	40	140	20	80	300	30	65	<b>S 607 C TA</b>
15	1950	750	150000	10	31	10	30	96	15	60	206	21	60	<b>SM 607 C TA</b>
15	1950	750	180000	10	31	7	30	96	13	60	206	20	70	<b>SH 607 C TA</b>
15	1800	700	135000	10	30	9	30	99	14	55	189	19	40	<b>BHT 607 C TAM</b>
15	3500	1500	115000	20	62	13	50	166	19	100	356	28	90	<b>S 627 C TA</b>
15	1750	640	100000	16	50	11	48	161	18	96	344	25	40	<b>BNT 627 C TAM</b>
15	1090	460	140000	5	15	8	16	55	13	35	123	17	30	<b>S 618/8 C TA</b>
15	2650	1140	125000	12	38	12	35	120	19	70	257	27	70	<b>S 619/8 C TA</b>
15	3500	1500	115000	17	52	12	50	165	20	100	355	28	90	<b>S 608 C TA</b>
15	2700	1100	136000	13	39	10	40	126	16	80	269	22	80	<b>SM 608 C TA</b>
15	2700	1100	163000	13	39	10	40	126	16	80	269	22	100	<b>SH 608 C TA</b>
15	2500	950	120000	12	36	9	35	112	14	70	236	19	80	<b>BHT 608 C TAM</b>
15	3500	1500	80000	17	52	12	50	165	20	100	355	28	60	<b>BHT 608 X - 2Z</b>
15	1130	500	130000	5	15	8	17	55	13	35	122	18	30	<b>S 618/9 C TA</b>
15	2850	1270	115000	12	38	13	40	137	21	75	274	29	70	<b>S 619/9 C TA</b>
15	3800	1700	102000	20	62	14	60	205	24	120	440	35	100	<b>S 609 C TA</b>
15	3000	1250	120000	16	48	12	50	163	20	100	345	27	90	<b>SM 609 C TA</b>
15	3000	1250	143000	16	48	12	50	163	20	100	345	27	110	<b>SH 609 C TA</b>
15	2800	1100	110000	15	45	11	45	146	18	90	311	24	80	<b>BHT 609 C TAM</b>
15	5600	2600	94000	30	96	19	80	277	30	160	596	42	140	<b>S 629 C TA</b>
15	5100	2300	83000	25	79	17	80	280	28	150	561	39	110	<b>BNT 629 C TAM</b>

Speed values shown are for oil-lubrication, with the exception of series BHT...X-2Z with grease lubrication

Boundary dimensions			Ball		Chamfer		Dimensions							Weight	Designation
d	D	B	D <sub>w</sub>	Z	r <sub>s_min</sub>	r' <sub>s_min</sub>	d <sub>1</sub>	d <sub>2</sub>	d <sub>k</sub>	d <sub>m</sub>	D <sub>1</sub>	D <sub>2</sub>	a	m	
10	19	5	2.381	13	0.3	0.2	12.80	-	14.45	14.50	16.20	16.90	-	0.005	<b>S 61800 C TA</b>
10	19	5	2.381	13	0.3	0.2	12.80	-	14.45	14.50	16.20	16.90	-	0.005	<b>S 61800 E TA</b>
10	22	6	3.175	11	0.3	0.3	13.60	-	15.80	16.00	17.80	18.80	-	0.010	<b>S 61900 C TA</b>
10	22	6	3.175	11	0.3	0.3	13.60	-	15.80	16.00	17.80	18.80	-	0.010	<b>S 61900 E TA</b>
10	22	6	2.381	14	0.3	0.3	13.60	13.30	15.40	16.00	17.80	18.50	-	0.010	<b>KH 61900 C TA</b>
10	22	6	2.381	14	0.3	0.3	13.60	13.30	15.40	16.00	17.80	18.50	-	0.010	<b>KH 61900 E TA</b>
10	26	8	4.762	10	0.3	0.3	14.65	-	18.40	18.00	21.40	22.70	-	0.018	<b>S 6000 C TA</b>
10	26	8	4.762	10	0.3	0.3	14.65	-	18.40	18.00	21.40	22.70	-	0.018	<b>S 6000 E TA</b>
10	26	8	3.175	11	0.3	0.3	14.65	14.20	17.20	18.00	20.50	21.30	-	0.018	<b>KH 6000 C TA</b>
10	26	8	3.175	11	0.3	0.3	14.65	14.20	17.20	18.00	20.50	21.30	-	0.018	<b>KH 6000 E TA</b>
10	26	8	4.762	10	0.3	0.3	14.65	-	18.40	18.00	21.40	22.70	-	0.018	<b>SM 6000 C TA</b>
10	26	8	4.762	10	0.3	0.3	14.65	13.80	18.40	18.00	21.40	22.70	-	0.018	<b>SH 6000 C TA</b>
10	26	8	4.762	10	0.3	0.3	14.65	-	18.40	18.00	21.40	22.70	3	0.018	<b>SMI 6000 C TA</b>
10	26	8	4.762	9	0.3	0.3	14.65	13.30	16.20	18.00	21.40	-	-	0.019	<b>BHT 6000 C TAM</b>
10	26	11.506	4.762	10	0.3	0.3	13.00	-	-	18.00	21.40	-	-	0.024	<b>BHT 6000 X - 2Z</b>
10	30	9	5.556	10	0.6	0.6	16.00	-	20.50	20.00	24.45	25.50	-	0.030	<b>S 6200 C TA</b>
10	30	9	5.556	10	0.6	0.6	16.00	-	20.50	20.00	24.45	25.50	-	0.030	<b>S 6200 E TA</b>
10	30	9	5.556	9	0.6	0.6	16.00	14.50	18.20	20.00	24.45	-	-	0.030	<b>BNT 6200 C TAM</b>
12	21	5	2.381	15	0.3	0.2	14.60	-	16.20	16.50	18.00	18.60	-	0.006	<b>S 61801 C TA</b>
12	21	5	2.381	15	0.3	0.2	14.60	-	16.20	16.50	18.00	18.60	-	0.006	<b>S 61801 E TA</b>
12	24	6	3.175	13	0.3	0.3	15.40	-	17.55	18.00	19.60	20.60	-	0.011	<b>S 61901 C TA</b>
12	24	6	3.175	13	0.3	0.3	15.40	-	17.55	18.00	19.60	20.60	-	0.011	<b>S 61901 E TA</b>
12	24	6	2.381	15	0.3	0.3	15.40	15.10	17.20	18.00	19.60	20.30	-	0.011	<b>KH 61901 C TA</b>
12	24	6	2.381	15	0.3	0.3	15.40	15.10	17.20	18.00	19.60	20.30	-	0.011	<b>KH 61901 E TA</b>
12	28	8	4.762	11	0.3	0.3	16.65	-	20.30	20.00	23.40	24.70	-	0.020	<b>S 6001 C TA</b>
12	28	8	4.762	11	0.3	0.3	16.65	-	20.30	20.00	23.40	24.70	-	0.020	<b>S 6001 E TA</b>
12	28	8	3.175	13	0.3	0.3	16.65	16.20	19.30	20.00	22.50	23.30	-	0.020	<b>KH 6001 C TA</b>
12	28	8	3.175	13	0.3	0.3	16.65	16.20	19.30	20.00	22.50	23.30	-	0.020	<b>KH 6001 E TA</b>
12	28	8	4.762	11	0.3	0.3	16.65	-	20.30	20.00	23.40	24.70	-	0.020	<b>SM 6001 C TA</b>
12	28	8	4.762	11	0.3	0.3	16.65	15.80	20.30	20.00	23.40	24.70	-	0.020	<b>SH 6001 C TA</b>
12	28	8	4.762	11	0.3	0.3	16.65	-	20.30	20.00	23.40	24.70	3	0.020	<b>SMI 6001 C TA</b>
12	28	8	4.762	10	0.3	0.3	16.65	15.30	18.20	20.00	23.40	-	-	0.021	<b>BHT 6001 C TAM</b>
12	28	11.506	4.762	11	0.3	0.3	15.00	-	-	20.00	23.40	-	-	0.027	<b>BHT 6001 X - 2Z</b>
12	32	10	5.953	10	0.6	0.6	18.30	-	22.60	22.00	26.00	27.90	-	0.037	<b>S 6201 C TA</b>
12	32	10	5.953	10	0.6	0.6	18.30	-	22.60	22.00	26.00	27.90	-	0.037	<b>S 6201 E TA</b>
12	32	10	5.953	9	0.6	0.6	18.30	16.00	19.80	22.00	26.00	-	-	0.037	<b>BNT 6201 C TAM</b>

Contact angle	Load rating		Speed value	Light preload			Medium preload			Heavy preload			Spring preload	Designation
	$\alpha_0$	C	$C_0$	n	$F_v$	$F_{a_{max}}$	$C_{ax}$	$F_v$	$F_{a_{max}}$	$C_{ax}$	$F_v$	$F_{a_{max}}$	$C_{ax}$	
15	1690	770	115000	8	25	10	25	83	17	50	177	23	40	<b>S 61800 C TA</b>
25	1610	730	100000	13	38	25	40	120	39	80	248	51	35	<b>S 61800 E TA</b>
15	2850	1280	110000	12	38	13	40	137	21	75	274	29	75	<b>S 61900 C TA</b>
25	2700	1100	92000	22	65	32	70	214	50	140	444	65	60	<b>S 61900 E TA</b>
15	1430	680	135000	7	20	12	21	66	18	45	147	25	50	<b>KH 61900 C TA</b>
25	1360	645	125000	11	33	25	35	104	37	70	211	49	40	<b>KH 61900 E TA</b>
15	5600	2600	95000	25	78	17	80	275	30	160	595	43	145	<b>S 6000 C TA</b>
25	5300	2400	80000	45	130	42	130	400	65	260	825	87	115	<b>S 6000 E TA</b>
15	2040	920	125000	10	30	12	30	92	19	60	194	26	65	<b>KH 6000 C TA</b>
25	1950	870	110000	16	47	26	50	151	39	100	306	51	60	<b>KH 6000 E TA</b>
15	4000	1700	111000	18	54	13	60	192	22	110	373	29	120	<b>SM 6000 C TA</b>
15	4000	1700	135000	18	54	13	60	192	22	110	373	29	150	<b>SH 6000 C TA</b>
15	4000	1700	155000	18	54	13	60	192	22	110	373	29	170	<b>SMI 6000 C TA</b>
15	3750	1550	100000	17	51	12	55	176	20	110	375	27	120	<b>BHT 6000 C TAM</b>
15	5600	2600	60000	25	78	17	80	275	30	160	595	43	90	<b>BHT 6000 X - 2Z</b>
15	7600	3700	85000	40	129	23	120	425	39	230	877	54	195	<b>S 6200 C TA</b>
25	7400	3500	72000	60	178	54	180	556	81	360	1156	110	160	<b>S 6200 E TA</b>
15	7000	3300	75000	35	113	20	100	352	33	200	760	47	160	<b>BNT 6200 C TAM</b>
15	1830	900	105000	9	28	12	25	82	18	55	194	26	50	<b>S 61801 C TA</b>
25	1740	850	89000	15	44	29	45	135	44	90	278	58	40	<b>S 61801 E TA</b>
15	3150	1530	97000	15	47	15	43	146	24	85	309	34	80	<b>S 61901 C TA</b>
25	3000	1300	83000	25	74	37	75	228	56	150	473	74	70	<b>S 61901 E TA</b>
15	1490	705	120000	7	22	12	22	67	19	45	148	26	50	<b>KH 61901 C TA</b>
25	1410	670	110000	12	35	26	35	105	39	70	210	51	45	<b>KH 61901 E TA</b>
15	6000	2900	85000	30	95	20	90	310	33	180	670	48	155	<b>S 6001 C TA</b>
25	5700	2700	72500	50	145	47	140	425	70	280	880	95	125	<b>S 6001 E TA</b>
15	2280	1110	110000	11	35	15	35	109	22	70	229	30	75	<b>KH 6001 C TA</b>
25	2180	1050	100000	18	51	30	55	164	45	110	333	59	65	<b>KH 6001 E TA</b>
15	4350	1900	100000	22	67	15	65	211	24	130	440	33	130	<b>SM 6001 C TA</b>
15	4350	1900	120000	22	67	15	65	211	24	130	440	33	160	<b>SH 6001 C TA</b>
15	4350	1900	140000	22	67	15	65	211	24	130	440	33	180	<b>SMI 6001 C TA</b>
15	4100	1750	90000	20	61	14	60	192	22	120	411	30	120	<b>BHT 6001 C TAM</b>
15	6000	2900	54000	30	95	20	90	310	33	180	670	48	100	<b>BHT 6001 X - 2Z</b>
15	8400	4100	77000	42	135	23	130	454	39	250	943	54	210	<b>S 6201 C TA</b>
25	8100	3900	66000	70	203	56	200	611	84	400	1280	112	180	<b>S 6201 E TA</b>
15	7800	3700	68000	40	129	21	120	422	35	240	912	50	175	<b>BNT 6201 C TAM</b>

Speed values shown are for oil-lubrication, with the exception of series BHT...X-2Z with grease lubrication

Boundary dimensions			Ball		Chamfer		Dimensions							Weight	Designation
d	D	B	D <sub>w</sub>	Z	r <sub>s_min</sub>	r' <sub>s_min</sub>	d <sub>1</sub>	d <sub>2</sub>	d <sub>k</sub>	d <sub>m</sub>	D <sub>1</sub>	D <sub>2</sub>	a	m	
15	24	5	2.381	17	0.3	0.2	17.80	-	19.30	19.50	21.20	21.80	-	0.007	<b>S 61802 C TA</b>
15	24	5	2.381	17	0.3	0.2	17.80	-	19.30	19.50	21.20	21.80	-	0.007	<b>S 61802 E TA</b>
15	28	7	3.969	13	0.3	0.3	18.70	-	21.65	21.50	24.30	25.40	-	0.015	<b>S 61902 C TA</b>
15	28	7	3.969	13	0.3	0.3	18.70	-	21.65	21.50	24.30	25.40	-	0.015	<b>S 61902 E TA</b>
15	28	7	2.778	16	0.3	0.3	18.70	18.3	21.00	21.50	23.90	24.50	-	0.015	<b>KH 61902 C TA</b>
15	28	7	2.778	16	0.3	0.3	18.70	18.3	21.00	21.50	23.90	24.50	-	0.015	<b>KH 61902 E TA</b>
15	32	9	4.762	13	0.3	0.3	20.15	-	23.70	23.50	26.90	28.20	-	0.028	<b>S 6002 C TA</b>
15	32	9	4.762	13	0.3	0.3	20.15	-	23.70	23.50	26.90	28.20	-	0.028	<b>S 6002 E TA</b>
15	32	9	3.969	13	0.3	0.3	20.15	19.4	23.10	23.50	26.70	28.00	-	0.028	<b>KH 6002 C TA</b>
15	32	9	3.969	13	0.3	0.3	20.15	19.4	23.10	23.50	26.70	28.00	-	0.028	<b>KH 6002 E TA</b>
15	32	9	4.762	13	0.3	0.3	20.15	-	23.70	23.50	26.90	28.20	-	0.028	<b>SM 6002 C TA</b>
15	32	9	4.762	13	0.3	0.3	20.15	19.3	23.70	23.50	26.90	28.20	-	0.028	<b>SH 6002 C TA</b>
15	32	9	4.762	13	0.3	0.3	20.15	-	23.70	23.50	26.90	28.20	3	0.028	<b>SMI 6002 C TA</b>
15	32	9	4.762	12	0.3	0.3	20.15	18.8	21.70	23.50	26.90	-	-	0.030	<b>BHT 6002 C TAM</b>
15	32	11.506	4.762	13	0.3	0.3	18.50	-	-	23.50	26.90	-	-	0.034	<b>BHT 6002 X - 2Z</b>
15	35	11	5.953	11	0.6	0.3	21.10	-	25.70	25.00	29.00	31.30	-	0.044	<b>S 6202 C TA</b>
15	35	11	5.953	11	0.6	0.3	21.10	-	25.70	25.00	29.00	31.30	-	0.044	<b>S 6202 E TA</b>
15	35	11	5.953	10	0.6	0.3	21.10	19.3	23.10	25.00	29.00	-	-	0.044	<b>BNT 6202 C TAM</b>
17	26	5	2.381	19	0.3	0.2	19.80	-	21.35	21.50	23.20	23.80	-	0.008	<b>S 61803 C TA</b>
17	26	5	2.381	19	0.3	0.2	19.80	-	21.35	21.50	23.20	23.80	-	0.008	<b>S 61803 E TA</b>
17	30	7	3.969	14	0.3	0.3	21.00	-	23.90	23.50	26.60	27.70	-	0.017	<b>S 61903 C TA</b>
17	30	7	3.969	14	0.3	0.3	21.00	-	23.90	23.50	26.60	27.70	-	0.017	<b>S 61903 E TA</b>
17	30	7	2.778	18	0.3	0.3	21.00	20.6	23.30	23.50	26.20	26.80	-	0.017	<b>KH 61903 C TA</b>
17	30	7	2.778	18	0.3	0.3	21.00	20.6	23.30	23.50	26.20	26.80	-	0.017	<b>KH 61903 E TA</b>
17	35	10	4.762	14	0.3	0.3	22.65	-	26.20	26.00	29.40	30.70	-	0.037	<b>S 6003 C TA</b>
17	35	10	4.762	14	0.3	0.3	22.65	-	26.20	26.00	29.40	30.70	-	0.037	<b>S 6003 E TA</b>
17	35	10	3.969	15	0.3	0.3	22.65	22.0	25.70	26.00	29.80	30.40	-	0.037	<b>KH 6003 C TA</b>
17	35	10	3.969	15	0.3	0.3	22.65	22.0	25.70	26.00	29.80	30.40	-	0.037	<b>KH 6003 E TA</b>
17	35	10	4.762	14	0.3	0.3	22.65	-	26.20	26.00	29.40	30.70	-	0.037	<b>SM 6003 C TA</b>
17	35	10	4.762	14	0.3	0.3	22.65	21.8	26.20	26.00	29.40	30.70	-	0.037	<b>SH 6003 C TA</b>
17	35	10	4.762	14	0.3	0.3	22.65	-	26.20	26.00	29.40	30.70	3	0.037	<b>SMI 6003 C TA</b>
17	35	10	4.762	13	0.3	0.3	22.65	21.3	24.20	26.00	29.40	-	-	0.039	<b>BHT 6003 C TAM</b>
17	35	12.7	4.762	14	0.3	0.3	21.00	-	-	26.00	29.40	-	-	0.046	<b>BHT 6003 X - 2Z</b>
17	40	12	6.747	11	0.6	0.3	24.10	-	29.00	28.50	32.95	35.20	-	0.065	<b>S 6203 C TA</b>
17	40	12	6.747	11	0.6	0.3	24.10	-	29.00	28.50	32.95	35.20	-	0.065	<b>S 6203 E TA</b>
17	40	12	6.747	10	0.6	0.3	24.10	21.8	26.10	28.50	32.95	-	-	0.065	<b>BNT 6203 C TAM</b>



Contact angle	Load rating		Speed value	Light preload			Medium preload			Heavy preload			Spring preload	Designation
	$\alpha_0$	C		$C_0$	n	$F_v$	$F_{a_{max}}$	$C_{ax}$	$F_v$	$F_{a_{max}}$	$C_{ax}$	$F_v$		
15	1930	1040	87000	10	31	13	30	99	21	60	211	29	50	<b>S 61802 C TA</b>
25	1820	980	74000	15	44	32	45	135	48	90	277	62	40	<b>S 61802 E TA</b>
15	4570	2160	79000	22	69	18	70	237	29	140	509	42	115	<b>S 61902 C TA</b>
25	4350	2050	67000	35	102	44	110	333	68	220	689	89	95	<b>S 61902 E TA</b>
15	2030	1030	100000	10	29	15	30	92	23	60	177	31	65	<b>KH 61902 C TA</b>
25	1930	980	90000	16	45	32	50	146	48	100	299	64	60	<b>KH 61902 E TA</b>
15	6800	3500	72000	32	100	22	100	340	38	200	740	55	175	<b>S 6002 C TA</b>
25	6400	3300	62000	55	160	54	160	490	82	320	1010	110	140	<b>S 6002 E TA</b>
15	3450	1710	92000	17	49	18	50	156	27	100	322	36	110	<b>KH 6002 C TA</b>
25	3300	1630	83000	30	89	39	80	238	55	160	484	72	95	<b>KH 6002 E TA</b>
15	4950	2300	85000	22	65	17	75	240	28	150	507	38	150	<b>SM 6002 C TA</b>
15	4950	2300	102000	22	65	17	75	240	28	150	507	38	170	<b>SH 6002 C TA</b>
15	4950	2300	120000	22	65	17	75	240	28	150	507	38	210	<b>SMI 6002 C TA</b>
15	4700	2150	77000	22	65	16	70	226	26	140	474	36	150	<b>BHT 6002 C TAM</b>
15	6800	3500	46000	32	100	22	100	340	38	200	740	55	110	<b>BHT 6002 X - 2Z</b>
15	9100	4600	67000	45	145	25	130	451	41	270	1013	59	230	<b>S 6202 C TA</b>
25	8800	4400	57000	75	223	61	220	673	93	440	1408	123	190	<b>S 6202 E TA</b>
15	8600	4200	59000	43	135	23	130	454	39	260	979	55	190	<b>BNT 6202 C TAM</b>
15	2040	1160	79000	10	31	14	30	98	22	60	208	31	50	<b>S 61803 C TA</b>
25	1920	1100	67000	16	47	35	50	149	54	100	307	69	40	<b>S 61803 E TA</b>
15	4770	2350	71000	25	78	20	75	254	32	150	545	45	120	<b>S 61903 C TA</b>
25	4500	2200	61000	40	117	49	120	364	73	240	752	96	100	<b>S 61903 E TA</b>
15	2170	1180	90000	11	32	17	35	108	27	65	211	34	70	<b>KH 61903 C TA</b>
25	2060	1110	82000	17	50	35	50	148	62	100	305	67	60	<b>KH 61903 E TA</b>
15	7000	3800	65000	35	110	24	105	360	41	210	775	59	180	<b>S 6003 C TA</b>
25	6700	3600	56000	60	175	58	170	515	88	340	1070	115	150	<b>S 6003 E TA</b>
15	3750	2020	82000	19	57	20	55	170	31	110	351	41	120	<b>KH 6003 C TA</b>
25	3600	1820	74000	30	90	42	90	265	63	180	546	82	105	<b>KH 6003 E TA</b>
15	5200	2500	77000	25	76	19	80	259	30	160	546	21	160	<b>SM 6003 C TA</b>
15	5200	2500	92000	25	76	19	80	259	30	160	546	21	190	<b>SH 6003 C TA</b>
15	5200	2500	110000	25	76	19	80	259	30	160	546	21	230	<b>SMI 6003 C TA</b>
15	4950	2350	69000	25	76	18	75	240	28	150	507	38	170	<b>BHT 6003 C TAM</b>
15	7000	3800	41000	35	110	24	105	360	41	210	775	59	110	<b>BHT 6003 X - 2Z</b>
15	11600	6000	60000	60	192	29	170	593	48	350	1321	69	300	<b>S 6203 C TA</b>
25	11200	5700	51000	90	266	69	280	861	106	560	1790	143	245	<b>S 6203 E TA</b>
15	10900	5500	53000	55	176	27	160	560	44	320	1208	63	250	<b>BNT 6203 C TAM</b>

Speed values shown are for oil-lubrication, with the exception of series BHT...X-2Z with grease lubrication

Boundary dimensions			Ball		Chamfer		Dimensions							Weight	Designation
d	D	B	D <sub>w</sub>	Z	r <sub>s_min</sub>	r' <sub>s_min</sub>	d <sub>1</sub>	d <sub>2</sub>	d <sub>k</sub>	d <sub>m</sub>	D <sub>1</sub>	D <sub>2</sub>	a	m	
20	32	7	3.175	18	0.3	0.3	23.90	-	25.95	26.00	28.10	29.10	-	0.018	<b>S 61804 C TA</b>
20	32	7	3.175	18	0.3	0.3	23.90	-	25.95	26.00	28.10	29.10	-	0.018	<b>S 61804 E TA</b>
20	37	9	4.762	15	0.3	0.3	25.10	-	28.65	28.50	31.90	33.20	-	0.036	<b>S 61904 C TA</b>
20	37	9	4.762	15	0.3	0.3	25.10	-	28.65	28.50	31.90	33.20	-	0.036	<b>S 61904 E TA</b>
20	37	9	3.969	16	0.3	0.3	25.10	24.50	28.00	28.50	31.70	33.00	-	0.036	<b>KH 61904 C TA</b>
20	37	9	3.969	16	0.3	0.3	25.10	24.50	28.00	28.50	31.70	33.00	-	0.036	<b>KH 61904 E TA</b>
20	42	12	6.350	13	0.6	0.3	26.60	-	31.40	31.00	35.50	37.30	-	0.063	<b>S 6004 C TA</b>
20	42	12	6.350	13	0.6	0.3	26.60	-	31.40	31.00	35.50	37.30	-	0.063	<b>S 6004 E TA</b>
20	42	12	5.556	14	0.6	0.3	26.60	25.25	30.50	31.00	36.40	38.00	-	0.063	<b>KH 6004 C TA</b>
20	42	12	5.556	14	0.6	0.3	26.60	25.25	30.50	31.00	36.40	38.00	-	0.063	<b>KH 6004 E TA</b>
20	42	12	6.350	13	0.6	0.3	26.60	-	31.40	31.00	35.50	37.30	-	0.063	<b>SM 6004 C TA</b>
20	42	12	6.350	13	0.6	0.3	26.60	25.40	31.40	31.00	35.50	37.30	-	0.063	<b>SH 6004 C TA</b>
20	42	12	6.350	13	0.6	0.3	26.60	-	31.40	31.00	35.50	37.30	3	0.063	<b>SMI 6004 C TA</b>
20	42	12	6.350	12	0.6	0.6	26.60	24.70	28.70	31.00	35.50	-	-	0.067	<b>BHT 6004 C TAM</b>
20	42	15.875	6.350	13	0.6	0.6	24.30	-	-	31.00	37.00	-	-	0.070	<b>BHT 6004 X-2Z</b>
20	47	14	7.938	11	1.0	0.6	28.50	-	34.20	33.50	38.55	41.40	-	0.105	<b>S 6204 C TA</b>
20	47	14	7.938	11	1.0	0.6	28.50	-	34.20	33.50	38.55	41.40	-	0.105	<b>S 6204 E TA</b>
20	47	14	7.938	10	1.0	0.6	28.50	25.60	30.90	33.50	38.55	-	-	0.105	<b>BNT 6204 C TAM</b>
25	37	7	3.175	19	0.3	0.3	28.90	-	30.90	31.00	33.10	34.10	-	0.021	<b>S 61805 C TA</b>
25	37	7	3.175	19	0.3	0.3	28.90	-	30.90	31.00	33.10	34.10	-	0.021	<b>S 61805 E TA</b>
25	42	9	4.762	17	0.3	0.3	30.60	-	34.10	33.50	37.40	38.70	-	0.041	<b>S 61905 C TA</b>
25	42	9	4.762	17	0.3	0.3	30.60	-	34.10	33.50	37.40	38.70	-	0.041	<b>S 61905 E TA</b>
25	42	9	3.969	19	0.3	0.3	30.60	30.00	33.50	33.50	37.20	38.50	-	0.041	<b>KH 61905 C TA</b>
25	42	9	3.969	19	0.3	0.3	30.60	30.00	33.50	33.50	37.20	38.50	-	0.041	<b>KH 61905 E TA</b>
25	47	12	6.350	15	0.6	0.3	32.20	-	36.30	36.00	40.10	42.30	-	0.076	<b>S 6005 C TA</b>
25	47	12	6.350	15	0.6	0.3	32.20	-	36.30	36.00	40.10	42.30	-	0.076	<b>S 6005 E TA</b>
25	47	12	5.556	17	0.6	0.3	32.20	30.85	36.10	36.00	42.00	43.60	-	0.076	<b>KH 6005 C TA</b>
25	47	12	5.556	17	0.6	0.3	32.20	30.85	36.10	36.00	42.00	43.60	-	0.076	<b>KH 6005 E TA</b>
25	47	12	6.350	15	0.6	0.3	32.20	-	36.30	36.00	40.10	42.30	-	0.076	<b>SM 6005 C TA</b>
25	47	12	6.350	15	0.6	0.3	32.20	30.40	36.30	36.00	40.10	42.30	-	0.076	<b>SH 6005 C TA</b>
25	47	12	6.350	15	0.6	0.3	32.20	-	36.30	36.00	40.10	42.30	3	0.076	<b>SMI 6005 C TA</b>
25	47	12	6.350	14	0.6	0.6	32.20	29.70	33.70	36.00	40.10	-	-	0.080	<b>BHT 6005 C TAM</b>
25	52	15	7.938	13	1.0	0.6	34.04	-	39.60	38.50	44.05	46.90	-	0.128	<b>S 6205 C TA</b>
25	52	15	7.938	13	1.0	0.6	34.04	-	39.60	38.50	44.05	46.90	-	0.128	<b>S 6205 E TA</b>
25	52	15	7.938	12	1.0	0.6	34.04	31.20	36.50	38.50	44.05	-	-	0.128	<b>BNT 6205 C TAM</b>

Contact angle	Load rating		Speed value	Light preload			Medium preload			Heavy preload			Spring preload	Designation
	$\alpha_0$	C	$C_0$	n	$F_v$	$F_{a_{max}}$	$C_{ax}$	$F_v$	$F_{a_{max}}$	$C_{ax}$	$F_v$	$F_{a_{max}}$	$C_{ax}$	
15	3700	2190	65000	19	59	21	55	186	32	110	397	45	95	<b>S 61804 C TA</b>
25	3500	2070	56000	30	88	49	90	273	74	170	530	95	75	<b>S 61804 E TA</b>
15	7350	3900	60000	35	110	26	110	377	43	220	811	61	190	<b>S 61904 C TA</b>
25	7000	3700	51000	55	161	62	170	517	95	340	1071	125	150	<b>S 61904 E TA</b>
15	3900	2080	75000	20	61	21	60	187	33	120	390	44	125	<b>KH 61904 C TA</b>
25	3700	1970	68000	30	89	44	90	263	66	180	542	85	110	<b>KH 61904 E TA</b>
15	12400	6900	55000	60	190	33	180	640	57	360	1380	84	320	<b>S 6004 C TA</b>
25	11900	6500	47000	100	300	78	300	930	120	600	1940	165	260	<b>S 6004 E TA</b>
15	6550	3600	70000	35	106	27	100	308	40	200	647	54	210	<b>KH 6004 C TA</b>
25	6300	3400	63000	50	142	54	160	479	82	320	975	106	180	<b>KH 6004 E TA</b>
15	8400	4150	65000	40	121	24	120	387	37	240	818	51	250	<b>SM 6004 C TA</b>
15	8400	4150	78000	40	121	24	120	387	37	240	818	51	300	<b>SH 6004 C TA</b>
15	8400	4150	90000	40	121	24	120	387	37	240	818	51	350	<b>SMI 6004 C TA</b>
15	7950	3800	58000	40	160	23	120	387	35	240	818	48	250	<b>BHT 6004 C TAM</b>
15	12400	6900	41000	60	190	33	180	640	57	360	1380	84	200	<b>BHT 6004 X-2Z</b>
15	17200	9300	51000	85	278	38	260	947	66	500	1968	94	440	<b>S 6204 C TA</b>
25	16500	8800	43000	140	419	91	410	1286	139	820	2688	189	360	<b>S 6204 E TA</b>
15	16000	8500	45000	80	263	35	240	876	61	480	1902	88	360	<b>BNT 6204 C TAM</b>
15	3700	2340	55000	19	59	21	55	185	33	110	395	46	95	<b>S 61805 C TA</b>
25	3500	2200	47000	30	88	51	90	272	76	170	529	98	75	<b>S 61805 E TA</b>
15	7800	4490	50000	40	126	29	120	410	48	240	881	67	200	<b>S 61905 C TA</b>
25	7400	4200	43000	60	176	70	180	546	105	360	1130	138	160	<b>S 61905 E TA</b>
15	4300	2550	63000	22	64	25	65	198	38	130	419	51	140	<b>KH 61905 C TA</b>
25	4100	2400	57000	35	98	52	100	289	76	200	597	99	120	<b>KH 61905 E TA</b>
15	13700	8100	47000	70	225	38	200	705	65	400	1520	95	350	<b>S 6005 C TA</b>
25	12900	7700	40000	110	325	88	320	990	135	640	2050	180	280	<b>S 6005 E TA</b>
15	7450	4500	59000	35	105	30	110	335	47	220	698	63	235	<b>KH 6005 C TA</b>
25	7100	4050	53000	60	173	65	180	537	96	360	1085	125	205	<b>KH 6005 E TA</b>
15	9300	4850	55000	50	152	28	140	447	43	280	945	59	300	<b>SM 6005 C TA</b>
15	9300	4850	67000	50	152	28	140	447	43	280	945	59	350	<b>SH 6005 C TA</b>
15	9300	4850	78000	50	152	28	140	447	43	280	945	59	400	<b>SMI 6005 C TA</b>
15	8850	4500	50000	45	138	26	130	417	40	260	882	55	300	<b>BHT 6005 C TAM</b>
15	19400	11200	44000	100	327	45	300	1090	77	600	2365	112	495	<b>S 6205 C TA</b>
25	18500	10600	37000	150	447	104	450	1405	159	900	2935	216	395	<b>S 6205 E TA</b>
15	18300	10400	38000	90	294	41	270	978	70	540	2122	102	402	<b>BNT 6205 C TAM</b>

Speed values for oil lubrication

Boundary dimensions			Ball		Chamfer		Dimensions							Weight	Designation
d	D	B	D <sub>w</sub>	Z	r <sub>s_min</sub>	r' <sub>s_min</sub>	d <sub>1</sub>	d <sub>2</sub>	d <sub>k</sub>	d <sub>m</sub>	D <sub>1</sub>	D <sub>2</sub>	a	m	
30	42	7	3.175	22	0.3	0.3	34.10	-	36.00	36.00	38.30	39.30	-	0.025	<b>S 61806 C TA</b>
30	42	7	3.175	22	0.3	0.3	34.10	-	36.00	36.00	38.30	39.30	-	0.025	<b>S 61806 E TA</b>
30	47	9	4.762	18	0.3	0.3	35.10	-	38.55	38.50	41.90	43.20	-	0.047	<b>S 61906 C TA</b>
30	47	9	4.762	18	0.3	0.3	35.10	-	38.55	38.50	41.90	43.20	-	0.047	<b>S 61906 E TA</b>
30	47	9	3.969	22	0.3	0.3	35.10	34.50	37.95	38.50	41.70	43.00	-	0.047	<b>KH 61906 C TA</b>
30	47	9	3.969	22	0.3	0.3	35.10	34.50	37.95	38.50	41.70	43.00	-	0.047	<b>KH 61906 E TA</b>
30	55	13	7.144	16	1.0	0.6	38.10	-	42.80	42.50	47.00	49.50	-	0.112	<b>S 6006 C TA</b>
30	55	13	7.144	16	1.0	0.6	38.10	-	42.80	42.50	47.00	49.50	-	0.112	<b>S 6006 E TA</b>
30	55	13	5.556	20	1.0	0.6	38.10	36.75	42.00	42.50	47.90	49.50	-	0.112	<b>KH 6006 C TA</b>
30	55	13	5.556	20	1.0	0.6	38.10	36.75	42.00	42.50	47.90	49.50	-	0.112	<b>KH 6006 E TA</b>
30	55	13	7.144	16	1.0	0.6	38.10	-	42.80	42.50	47.00	49.50	-	0.112	<b>SM 6006 C TA</b>
30	55	13	7.144	16	1.0	0.6	38.10	36.20	42.80	42.50	47.00	49.50	-	0.112	<b>SH 6006 C TA</b>
30	55	13	7.144	16	1.0	0.6	38.10	-	42.80	42.50	47.00	49.50	3	0.112	<b>SMI 6006 C TA</b>
30	55	13	7.144	15	1.0	0.6	38.10	35.40	40.00	42.50	47.00	-	-	0.117	<b>BHT 6006 C TAM</b>
30	62	16	9.525	13	1.0	0.6	40.40	-	46.70	46.00	52.05	55.40	-	0.199	<b>S 6206 C TA</b>
30	62	16	9.525	13	1.0	0.6	40.40	-	46.70	46.00	52.05	55.40	-	0.199	<b>S 6206 E TA</b>
30	62	16	9.525	12	1.0	0.6	40.40	36.50	43.00	46.00	52.05	-	-	0.199	<b>BNT 6206 C TAM</b>
35	47	7	3.175	24	0.3	0.3	38.90	-	40.85	41.00	43.10	44.10	-	0.028	<b>S 61807 C TA</b>
35	47	7	3.175	24	0.3	0.3	38.90	-	40.85	41.00	43.10	44.10	-	0.028	<b>S 61807 E TA</b>
35	55	10	5.556	18	0.6	0.3	41.40	-	45.10	45.00	48.60	50.40	-	0.075	<b>S 61907 C TA</b>
35	55	10	5.556	18	0.6	0.3	41.40	-	45.10	45.00	48.60	50.40	-	0.075	<b>S 61907 E TA</b>
35	55	10	3.969	26	0.6	0.3	41.40	40.80	44.60	45.00	48.10	49.40	-	0.075	<b>KH 61907 C TA</b>
35	55	10	3.969	26	0.6	0.3	41.40	40.80	44.60	45.00	48.10	49.40	-	0.075	<b>KH 61907 E TA</b>
35	62	14	7.938	16	1.0	0.6	43.20	-	48.90	48.50	53.10	56.30	-	0.149	<b>S 6007 C TA</b>
35	62	14	7.938	16	1.0	0.6	43.20	-	48.90	48.50	53.10	56.30	-	0.149	<b>S 6007 E TA</b>
35	62	14	6.350	20	1.0	0.6	43.20	41.50	47.70	48.50	53.60	56.00	-	0.149	<b>KH 6007 C TA</b>
35	62	14	6.350	20	1.0	0.6	43.20	41.50	47.70	48.50	53.60	56.00	-	0.149	<b>KH 6007 E TA</b>
35	62	14	7.938	16	1.0	0.6	43.20	-	48.90	48.50	53.10	56.30	-	0.149	<b>SM 6007 C TA</b>
35	62	14	7.938	16	1.0	0.6	43.20	41.50	48.90	48.50	53.10	56.30	-	0.149	<b>SH 6007 C TA</b>
35	62	14	7.938	16	1.0	0.6	43.20	-	48.90	48.50	53.10	56.30	4	0.149	<b>SMI 6007 C TA</b>
35	72	17	11.112	13	1.1	0.6	47.40	-	54.40	53.50	60.55	64.50	-	0.290	<b>S 6207 C TA</b>
35	72	17	11.112	13	1.1	0.6	47.40	-	54.40	53.50	60.55	64.50	-	0.290	<b>S 6207 E TA</b>

Contact angle	Load rating		Speed value	Light preload			Medium preload			Heavy preload			Spring preload	Designation
	$\alpha_0$	C	$C_0$	n	$F_v$	$F_{a_{max}}$	$C_{ax}$	$F_v$	$F_{a_{max}}$	$C_{ax}$	$F_v$	$F_{a_{max}}$	$C_{ax}$	
15	3900	2750	47000	20	62	24	60	200	37	120	428	52	100	<b>S 61806 C TA</b>
25	3700	2550	40000	30	88	56	90	270	76	180	557	109	80	<b>S 61806 E TA</b>
15	7940	4800	44000	40	125	30	120	408	50	240	875	69	200	<b>S 61906 C TA</b>
25	7500	4500	38000	60	176	72	190	577	111	380	1193	146	165	<b>S 61906 E TA</b>
15	4650	3000	55000	23	66	28	70	215	43	140	446	57	150	<b>KH 61906 C TA</b>
25	4400	2850	50000	35	97	58	110	322	87	220	657	112	130	<b>KH 61906 E TA</b>
15	16800	10500	40000	85	270	43	250	860	72	500	1870	105	430	<b>S 6006 C TA</b>
25	16000	9900	34000	130	380	98	400	1220	150	800	2540	205	350	<b>S 6006 E TA</b>
15	8300	5150	50000	40	118	35	120	369	54	250	798	73	265	<b>KH 6006 C TA</b>
25	7800	4900	46000	65	192	74	200	582	111	390	1165	143	225	<b>KH 6006 E TA</b>
15	12100	6700	47000	60	179	32	180	574	50	360	1221	69	350	<b>SM 6006 C TA</b>
15	12100	6700	57000	60	179	32	180	574	50	360	1221	69	450	<b>SH 6006 C TA</b>
15	12100	6700	66000	60	179	32	180	574	50	360	1221	69	500	<b>SMI 6006 C TA</b>
15	11600	6250	42000	60	183	31	170	546	47	340	1145	65	350	<b>BHT 6006 C TAM</b>
15	25500	15200	37000	130	418	49	380	1339	82	760	2892	117	650	<b>S 6206 C TA</b>
25	24300	14300	32000	200	592	117	600	1851	177	1200	3851	239	540	<b>S 6206 E TA</b>
15	24200	14000	33000	120	385	46	360	1272	77	720	2748	110	550	<b>BNT 6206 C TAM</b>
15	4000	3000	41000	20	62	25	60	199	39	120	424	54	100	<b>S 61807 C TA</b>
25	3800	2800	35000	30	87	58	90	271	93	190	587	118	80	<b>S 61807 E TA</b>
15	11000	6940	38000	55	174	37	165	569	61	330	1225	86	280	<b>S 61907 C TA</b>
25	10400	6500	32000	90	265	91	260	794	135	520	1647	177	225	<b>S 61907 E TA</b>
15	5100	3600	47000	25	73	32	80	246	50	150	472	64	165	<b>KH 61907 C TA</b>
25	4800	3400	43000	40	114	67	120	350	99	240	736	129	140	<b>KH 61907 E TA</b>
15	20900	13500	35000	100	315	50	300	1040	84	600	2240	120	555	<b>S 6007 C TA</b>
25	19900	12700	30000	170	500	118	500	1530	180	1000	3190	245	450	<b>S 6007 E TA</b>
15	10500	6700	44000	50	148	40	160	490	62	320	1026	82	335	<b>KH 6007 C TA</b>
25	10000	6350	40000	80	228	83	250	743	125	500	1491	162	290	<b>KH 6007 E TA</b>
15	14500	8200	41000	70	211	37	210	671	57	420	1404	77	450	<b>SM 6007 C TA</b>
15	14500	8200	50000	70	211	37	210	671	57	420	1404	77	550	<b>SH 6007 C TA</b>
15	14500	8200	58000	70	211	37	210	671	57	420	1404	77	650	<b>SMI 6007 C TA</b>
15	35200	21800	32000	180	585	60	530	1899	102	1000	3853	142	905	<b>S 6207 C TA</b>
25	33700	20800	27000	280	833	142	840	2613	217	1700	5521	296	730	<b>S 6207 E TA</b>

Speed values for oil lubrication

Boundary dimensions			Ball		Chamfer		Dimensions							Weight	Designation
d	D	B	D <sub>w</sub>	Z	r <sub>s_min</sub>	r' <sub>s_min</sub>	d <sub>1</sub>	d <sub>2</sub>	d <sub>k</sub>	d <sub>m</sub>	D <sub>1</sub>	D <sub>2</sub>	a	m	
40	52	7	3.175	26	0.3	0.3	43.90	-	45.85	46.00	48.10	49.10	-	0.031	<b>S 61808 C TA</b>
40	52	7	3.175	26	0.3	0.3	43.90	-	45.85	46.00	48.10	49.10	-	0.031	<b>S 61808 E TA</b>
40	62	12	6.350	19	0.6	0.3	46.80	-	51.15	51.00	55.20	57.20	-	0.109	<b>S 61908 C TA</b>
40	62	12	6.350	19	0.6	0.3	46.80	-	51.15	51.00	55.20	57.20	-	0.109	<b>S 61908 E TA</b>
40	62	12	4.762	25	0.6	0.3	46.80	45.30	49.80	51.00	55.20	56.70	-	0.109	<b>KH 61908 C TA</b>
40	62	12	4.762	25	0.6	0.3	46.80	45.30	49.80	51.00	55.20	56.70	-	0.109	<b>KH 61908 E TA</b>
40	68	15	7.938	18	1.0	0.6	49.20	-	54.30	54.00	59.00	61.80	-	0.185	<b>S 6008 C TA</b>
40	68	15	7.938	18	1.0	0.6	49.20	-	54.30	54.00	59.00	61.80	-	0.185	<b>S 6008 E TA</b>
40	68	15	6.350	22	1.0	0.6	49.20	47.50	53.50	54.00	60.20	62.60	-	0.185	<b>KH 6008 C TA</b>
40	68	15	6.350	22	1.0	0.6	49.20	47.50	53.50	54.00	60.20	62.60	-	0.185	<b>KH 6008 E TA</b>
40	68	15	7.938	18	1.0	0.6	49.20	-	54.30	54.00	59.00	61.80	-	0.185	<b>SM 6008 C TA</b>
40	68	15	7.938	18	1.0	0.6	49.20	47.00	54.30	54.00	59.00	61.80	-	0.185	<b>SH 6008 C TA</b>
40	68	15	7.938	18	1.0	0.6	49.20	-	54.30	54.00	59.00	61.80	4	0.185	<b>SMI 6008 C TA</b>
40	80	18	11.906	13	1.1	0.6	52.80	-	60.90	60.00	67.60	71.80	-	0.368	<b>S 6208 C TA</b>
40	80	18	11.906	13	1.1	0.6	52.80	-	60.90	60.00	67.60	71.80	-	0.368	<b>S 6208 E TA</b>
45	58	7	3.175	28	0.3	0.3	49.40	-	51.30	51.50	53.60	54.60	-	0.039	<b>S 61809 C TA</b>
45	58	7	3.175	28	0.3	0.3	49.40	-	51.30	51.50	53.60	54.60	-	0.039	<b>S 61809 E TA</b>
45	68	12	6.350	20	0.6	0.3	52.30	-	56.60	56.50	60.70	62.70	-	0.128	<b>S 61909 C TA</b>
45	68	12	6.350	20	0.6	0.3	52.30	-	56.60	56.50	60.70	62.70	-	0.128	<b>S 61909 E TA</b>
45	68	12	4.762	28	0.6	0.3	52.30	50.8	55.25	56.50	60.70	62.20	-	0.128	<b>KH 61909 C TA</b>
45	68	12	4.762	28	0.6	0.3	52.30	50.8	55.25	56.50	60.70	62.20	-	0.128	<b>KH 61909 E TA</b>
45	75	16	8.731	18	1.0	0.6	54.70	-	60.40	60.00	65.00	68.60	-	0.238	<b>S 6009 C TA</b>
45	75	16	8.731	18	1.0	0.6	54.70	-	60.40	60.00	65.00	68.60	-	0.238	<b>S 6009 E TA</b>
45	75	16	6.350	22	1.0	0.6	54.70	53.0	59.10	60.00	65.60	67.75	-	0.238	<b>KH 6009 C TA</b>
45	75	16	6.350	22	1.0	0.6	54.70	53.0	59.10	60.00	65.60	67.75	-	0.238	<b>KH 6009 E TA</b>
45	75	16	8.731	18	1.0	0.6	54.70	-	60.40	60.00	65.00	68.60	-	0.238	<b>SM 6009 C TA</b>
45	75	16	8.731	18	1.0	0.6	54.70	52.3	60.40	60.00	65.00	68.60	-	0.238	<b>SH 6009 C TA</b>
45	75	16	8.731	18	1.0	0.6	54.70	-	60.40	60.00	65.00	68.60	4	0.238	<b>SMI 6009 C TA</b>
45	85	19	12.700	14	1.1	0.6	57.40	-	66.00	65.00	72.45	77.50	-	0.416	<b>S 6209 C TA</b>
45	85	19	12.700	14	1.1	0.6	57.40	-	66.00	65.00	72.45	77.50	-	0.416	<b>S 6209 E TA</b>

Contact angle	Load rating		Speed value	Light preload			Medium preload			Heavy preload			Spring preload	Designation
	$\alpha_0$	C	$C_0$	n	$F_v$	$F_{a_{max}}$	$C_{ax}$	$F_v$	$F_{a_{max}}$	$C_{ax}$	$F_v$	$F_{a_{max}}$	$C_{ax}$	
15	4100	3250	37000	21	65	27	60	198	41	120	421	57	105	<b>S 61808 C TA</b>
25	3850	3050	32000	30	87	62	100	300	97	190	585	124	85	<b>S 61808 E TA</b>
15	15200	10100	33000	75	239	46	230	804	77	460	1735	109	385	<b>S 61908 C TA</b>
25	14300	9500	28500	120	354	111	360	1106	168	720	2298	225	315	<b>S 61908 E TA</b>
15	6950	4950	42000	35	102	37	100	303	55	210	664	75	220	<b>KH 61908 C TA</b>
25	6550	4650	38000	55	163	77	160	477	113	330	998	148	190	<b>KH 61908 E TA</b>
15	22400	15300	31500	110	350	53	330	1150	91	660	2480	130	570	<b>S 6008 C TA</b>
25	21200	14500	27000	180	530	125	530	1630	190	1100	3520	265	465	<b>S 6008 E TA</b>
15	11000	7500	39000	55	163	44	160	486	65	330	1054	88	350	<b>KH 6008 C TA</b>
25	10500	7100	36000	90	264	92	260	756	135	520	1560	175	300	<b>KH 6008 E TA</b>
15	15600	9300	37000	80	242	40	230	732	61	460	1563	83	450	<b>SM 6008 C TA</b>
15	15600	9300	45000	80	242	40	230	732	61	460	1563	83	550	<b>SH 6008 C TA</b>
15	15600	9300	52000	80	242	40	230	732	61	460	1563	83	650	<b>SMI 6008 C TA</b>
15	37200	22900	28500	185	588	58	560	1949	98	1100	4119	137	950	<b>S 6208 C TA</b>
25	35400	22000	24000	300	886	142	900	2763	215	1800	5740	288	765	<b>S 6208 E TA</b>
15	4200	3500	33000	21	64	28	65	214	44	130	456	61	110	<b>S 61809 C TA</b>
25	3950	3300	28000	35	102	68	100	299	102	200	615	132	85	<b>S 61809 E TA</b>
15	15400	10700	30000	80	255	49	230	800	79	460	1725	112	390	<b>S 61909 C TA</b>
25	14500	10100	25500	120	354	115	360	1104	173	720	2291	232	315	<b>S 61909 E TA</b>
15	7350	5550	38000	35	102	40	110	339	61	220	689	81	235	<b>KH 61909 C TA</b>
25	6950	5250	34000	60	170	86	170	497	124	350	1042	162	200	<b>KH 61909 E TA</b>
15	27400	19200	28000	130	415	60	400	1410	105	800	3050	150	690	<b>S 6009 C TA</b>
25	26000	18100	24000	210	620	140	650	2010	220	1300	4180	300	560	<b>S 6009 E TA</b>
15	10900	7600	36000	55	163	44	160	486	65	330	1040	88	345	<b>KH 6009 C TA</b>
25	10300	7200	32000	90	265	92	260	756	135	520	1560	175	295	<b>KH 6009 E TA</b>
15	18800	11400	33000	90	273	44	275	883	69	550	1777	93	550	<b>SM 6009 C TA</b>
15	18800	11400	40000	90	273	44	275	883	69	550	1777	93	700	<b>SH 6009 C TA</b>
15	18800	11400	47000	90	273	44	275	883	69	550	1777	93	800	<b>SMI 6009 C TA</b>
15	45900	29900	26000	230	740	71	700	2481	119	1400	5366	171	1165	<b>S 6209 C TA</b>
25	43800	28500	22500	370	1097	169	1100	3403	257	2200	7085	346	960	<b>S 6209 E TA</b>

Speed values for oil lubrication

Boundary dimensions			Ball		Chamfer		Dimensions							Weight	Designation
d	D	B	D <sub>w</sub>	Z	r <sub>s_min</sub>	r' <sub>s_min</sub>	d <sub>1</sub>	d <sub>2</sub>	d <sub>k</sub>	d <sub>m</sub>	D <sub>1</sub>	D <sub>2</sub>	a	m	
50	65	7	3.969	26	0.3	0.3	54.70	-	57.35	57.50	60.30	61.30	-	0.049	<b>S 61810 C TA</b>
50	65	7	3.969	26	0.3	0.3	54.70	-	57.35	57.50	60.30	61.30	-	0.049	<b>S 61810 E TA</b>
50	72	12	6.350	21	0.6	0.3	56.80	-	61.05	61.00	65.20	67.20	-	0.129	<b>S 61910 C TA</b>
50	72	12	6.350	21	0.6	0.3	56.80	-	61.05	61.00	65.20	67.20	-	0.129	<b>S 61910 E TA</b>
50	72	12	4.762	30	0.6	0.3	56.80	55.30	59.75	61.00	65.20	66.70	-	0.129	<b>KH 61910 C TA</b>
50	72	12	4.762	30	0.6	0.3	56.80	55.30	59.75	61.00	65.20	66.70	-	0.129	<b>KH 61910 E TA</b>
50	80	16	8.731	19	1.0	0.6	59.70	-	65.30	65.00	70.00	73.60	-	0.256	<b>S 6010 C TA</b>
50	80	16	8.731	19	1.0	0.6	59.70	-	65.30	65.00	70.00	73.60	-	0.256	<b>S 6010 E TA</b>
50	80	16	6.350	25	1.0	0.6	59.70	58.00	64.00	65.00	70.70	73.10	-	0.256	<b>KH 6010 C TA</b>
50	80	16	6.350	25	1.0	0.6	59.70	58.00	64.00	65.00	70.70	73.10	-	0.256	<b>KH 6010 E TA</b>
50	80	16	8.731	19	1.0	0.6	59.70	-	65.30	65.00	70.00	73.60	-	0.256	<b>SM 6010 C TA</b>
50	80	16	8.731	19	1.0	0.6	59.70	57.30	65.30	65.00	70.00	73.60	-	0.256	<b>SH 6010 C TA</b>
50	80	16	8.731	19	1.0	0.6	59.70	-	65.30	65.00	70.00	73.60	4	0.256	<b>SMI 6010 C TA</b>
50	90	20	12.700	15	1.1	0.6	62.45	-	70.90	70.00	76.90	82.70	-	0.486	<b>S 6210 C TA</b>
50	90	20	12.700	15	1.1	0.6	62.45	-	70.90	70.00	76.90	82.70	-	0.486	<b>S 6210 E TA</b>
55	72	9	4.762	26	0.3	0.3	60.10	-	63.40	63.50	66.90	68.10	-	0.077	<b>S 61811 C TA</b>
55	72	9	4.762	26	0.3	0.3	60.10	-	63.40	63.50	66.90	68.10	-	0.077	<b>S 61811 E TA</b>
55	80	13	7.144	21	1.0	0.3	63.10	-	67.60	67.50	71.90	74.50	-	0.181	<b>S 61911 C TA</b>
55	80	13	7.144	21	1.0	0.3	63.10	-	67.60	67.50	71.90	74.50	-	0.181	<b>S 61911 E TA</b>
55	80	13	5.556	30	1.0	0.3	63.10	61.75	66.80	67.50	72.90	74.50	-	0.181	<b>KH 61911 C TA</b>
55	80	13	5.556	30	1.0	0.3	63.10	61.75	66.80	67.50	72.90	74.50	-	0.181	<b>KH 61911 E TA</b>
55	90	18	9.525	20	1.1	1.0	66.80	-	72.80	72.50	78.20	81.90	-	0.374	<b>S 6011 C TA</b>
55	90	18	9.525	20	1.1	1.0	66.80	-	72.80	72.50	78.20	81.90	-	0.374	<b>S 6011 E TA</b>
55	90	18	7.938	23	1.1	1.0	66.80	65.60	71.80	72.50	79.20	82.40	-	0.374	<b>KH 6011 C TA</b>
55	90	18	7.938	23	1.1	1.0	66.80	65.60	71.80	72.50	79.20	82.40	-	0.374	<b>KH 6011 E TA</b>
55	90	18	9.525	20	1.1	1.0	66.80	-	72.80	72.50	78.20	81.90	-	0.374	<b>SM 6011 C TA</b>
55	90	18	9.525	20	1.1	1.0	66.80	63.60	72.80	72.50	78.20	81.90	-	0.374	<b>SH 6011 C TA</b>
55	90	18	9.525	20	1.1	1.0	66.80	-	72.80	72.50	78.20	81.90	4	0.374	<b>SMI 6011 C TA</b>
55	100	21	14.288	15	1.5	1.0	69.00	-	78.60	77.50	85.80	91.60	-	0.621	<b>S 6211 C TA</b>
55	100	21	14.288	15	1.5	1.0	69.00	-	78.60	77.50	85.80	91.60	-	0.621	<b>S 6211 E TA</b>



Contact angle	Load rating		Speed value	Light preload			Medium preload			Heavy preload			Spring preload	Designation
	$\alpha_0$	C	$C_0$	n	$F_v$	$F_{a_{max}}$	$C_{ax}$	$F_v$	$F_{a_{max}}$	$C_{ax}$	$F_v$	$F_{a_{max}}$	$C_{ax}$	
15	6000	4850	29500	30	92	31	90	294	49	180	625	68	155	<b>S 61810 C TA</b>
25	5650	4600	25000	45	131	75	140	417	114	300	921	153	120	<b>S 61810 E TA</b>
15	15600	11300	28000	80	254	50	230	796	81	460	1715	115	400	<b>S 61910 C TA</b>
25	14700	10600	24000	120	354	119	370	1133	180	740	2351	241	325	<b>S 61910 E TA</b>
15	7600	6000	35000	40	116	44	110	333	64	230	724	86	240	<b>KH 61910 C TA</b>
25	7150	5650	32000	60	169	90	180	532	132	360	1064	171	205	<b>KH 61910 E TA</b>
15	28200	20200	26000	140	450	64	420	1480	110	840	3200	160	715	<b>S 6010 C TA</b>
25	26600	19300	22000	220	650	145	670	2060	230	1330	4270	310	570	<b>S 6010 E TA</b>
15	11700	8700	33000	60	177	49	180	553	74	350	1132	98	370	<b>KH 6010 C TA</b>
25	11100	8200	30000	90	256	100	280	814	150	560	1682	194	320	<b>KH 6010 E TA</b>
15	19300	12100	31000	100	303	47	290	921	72	580	1947	99	600	<b>SM 6010 C TA</b>
15	19300	12100	37000	100	303	47	290	921	72	580	1947	99	700	<b>SH 6010 C TA</b>
15	19300	12100	43000	100	303	47	290	921	72	580	1947	99	800	<b>SMI 6010 C TA</b>
15	48000	32600	24500	240	767	75	720	2556	125	1440	5506	178	1150	<b>S 6210 C TA</b>
25	45700	30800	20500	380	1115	177	1140	3529	271	2280	7349	363	910	<b>S 6210 E TA</b>
15	9000	7500	27000	45	139	40	140	467	64	250	880	85	230	<b>S 61811 C TA</b>
25	8500	7050	23000	70	204	97	210	631	145	400	1235	186	190	<b>S 61811 E TA</b>
15	18700	13700	25000	90	282	52	280	957	87	560	2056	122	475	<b>S 61911 C TA</b>
25	17600	12900	21500	150	441	130	440	1338	193	880	2770	257	380	<b>S 61911 E TA</b>
15	10100	8200	31000	50	146	50	150	456	75	300	937	99	320	<b>KH 61911 C TA</b>
25	9600	7700	28500	80	226	104	240	706	154	480	1432	199	275	<b>KH 61911 E TA</b>
15	32600	24600	23500	160	501	69	490	1698	115	980	3671	163	840	<b>S 6011 C TA</b>
25	30800	23100	20000	260	769	167	770	2354	253	1540	4881	337	670	<b>S 6011 E TA</b>
15	16800	12400	29500	80	234	55	250	762	84	500	1577	111	530	<b>KH 6011 C TA</b>
25	15900	11700	26500	130	371	115	400	1162	172	800	2396	223	455	<b>KH 6011 E TA</b>
15	23500	15300	27000	115	365	52	350	1108	81	700	2373	110	700	<b>SM 6011 C TA</b>
15	23500	15300	33000	115	365	52	350	1108	81	700	2373	110	850	<b>SH 6011 C TA</b>
15	23500	15300	39000	115	365	52	350	1108	81	700	2373	110	1000	<b>SMI 6011 C TA</b>
15	59000	40600	22000	300	961	83	900	3165	139	1800	6836	199	1510	<b>S 6211 C TA</b>
25	56300	38600	18500	470	1390	198	1400	4312	300	2800	8967	404	1210	<b>S 6211 E TA</b>

Speed values for oil lubrication

Boundary dimensions			Ball		Chamfer		Dimensions							Weight	Designation
d	D	B	D <sub>w</sub>	Z	r <sub>s_min</sub>	r' <sub>s_min</sub>	d <sub>1</sub>	d <sub>2</sub>	d <sub>k</sub>	d <sub>m</sub>	D <sub>1</sub>	D <sub>2</sub>	a	m	
60	78	10	4.762	28	0.3	0.3	65.6	-	68.90	69.00	72.40	73.60	-	0.100	<b>S 61812 C TA</b>
60	78	10	4.762	28	0.3	0.3	65.6	-	68.90	69.00	72.40	73.60	-	0.100	<b>S 61812 E TA</b>
60	85	13	7.144	23	1.0	0.3	68.1	-	72.60	72.50	76.90	79.50	-	0.195	<b>S 61912 C TA</b>
60	85	13	7.144	23	1.0	0.3	68.1	-	72.60	72.50	76.90	79.50	-	0.195	<b>S 61912 E TA</b>
60	85	13	5.556	32	1.0	0.3	68.1	66.75	71.80	72.50	77.90	79.50	-	0.195	<b>KH 61912 C TA</b>
60	85	13	5.556	32	1.0	0.3	68.1	66.75	71.80	72.50	77.90	79.50	-	0.195	<b>KH 61912 E TA</b>
60	95	18	9.525	22	1.1	1.0	71.9	-	77.80	77.50	83.20	87.00	-	0.406	<b>S 6012 C TA</b>
60	95	18	9.525	22	1.1	1.0	71.9	-	77.80	77.50	83.20	87.00	-	0.406	<b>S 6012 E TA</b>
60	95	18	7.938	24	1.1	1.0	71.9	70.70	76.80	77.50	84.20	87.40	-	0.406	<b>KH 6012 C TA</b>
60	95	18	7.938	24	1.1	1.0	71.9	70.70	76.80	77.50	84.20	87.40	-	0.406	<b>KH 6012 E TA</b>
60	95	18	9.525	22	1.1	1.0	71.9	-	77.80	77.50	83.20	87.00	-	0.406	<b>SM 6012 C TA</b>
60	95	18	9.525	22	1.1	1.0	71.9	69.10	77.80	77.50	83.20	87.00	-	0.406	<b>SH 6012 C TA</b>
60	95	18	9.525	22	1.1	1.0	71.9	-	77.80	77.50	83.20	87.00	4	0.406	<b>SMI 6012 C TA</b>
60	110	22	15.875	15	1.5	1.0	76.0	-	86.90	85.00	95.50	101.40	-	0.795	<b>S 6212 C TA</b>
60	110	22	15.875	15	1.5	1.0	76.0	-	86.90	85.00	95.50	101.40	-	0.795	<b>S 6212 E TA</b>
65	85	10	5.556	27	0.6	0.3	71.4	-	74.95	75.00	78.60	80.40	-	0.122	<b>S 61813 C TA</b>
65	85	10	5.556	27	0.6	0.3	71.4	-	74.95	75.00	78.60	80.40	-	0.122	<b>S 61813 E TA</b>
65	90	13	7.144	24	1.0	0.3	73.1	-	77.60	77.50	81.90	84.50	-	0.207	<b>S 61913 C TA</b>
65	90	13	7.144	24	1.0	0.3	73.1	-	77.60	77.50	81.90	84.50	-	0.207	<b>S 61913 E TA</b>
65	90	13	5.556	34	1.0	0.3	73.1	71.75	76.80	77.50	82.90	84.50	-	0.207	<b>KH 61913 C TA</b>
65	90	13	5.556	34	1.0	0.3	73.1	71.75	76.80	77.50	82.90	84.50	-	0.207	<b>KH 61913 E TA</b>
65	100	18	9.525	23	1.1	1.0	76.9	-	82.80	82.50	88.20	92.00	-	0.431	<b>S 6013 C TA</b>
65	100	18	9.525	23	1.1	1.0	76.9	-	82.80	82.50	88.20	92.00	-	0.431	<b>S 6013 E TA</b>
65	100	18	7.938	25	1.1	1.0	76.9	75.70	81.70	82.50	89.20	92.40	-	0.431	<b>KH 6013 C TA</b>
65	100	18	7.938	25	1.1	1.0	76.9	75.70	81.70	82.50	89.20	92.40	-	0.431	<b>KH 6013 E TA</b>
65	100	18	9.525	23	1.1	1.0	76.9	-	82.80	82.50	88.20	92.00	-	0.431	<b>SM 6013 C TA</b>
65	100	18	9.525	23	1.1	1.0	76.9	74.05	82.80	82.50	88.20	92.00	-	0.431	<b>SH 6013 C TA</b>
65	100	18	9.525	23	1.1	1.0	76.9	-	82.80	82.50	88.20	92.00	4	0.431	<b>SMI 6013 C TA</b>
65	120	23	15.875	16	1.5	1.1	82.8	-	93.70	92.50	102.30	108.50	-	1.008	<b>S 6213 C TA</b>
65	120	23	15.875	16	1.5	1.1	82.8	-	93.70	92.50	102.30	108.50	-	1.008	<b>S 6213 E TA</b>

Contact angle	Load rating		Speed value	Light preload			Medium preload			Heavy preload			Spring preload	Designation
	$\alpha_0$	C	$C_0$	n	$F_v$	$F_{a_{max}}$	$C_{ax}$	$F_v$	$F_{a_{max}}$	$C_{ax}$	$F_v$	$F_{a_{max}}$	$C_{ax}$	
15	9300	8100	24500	45	139	41	140	464	66	300	1068	97	1240	<b>S 61812 C TA</b>
25	8700	7600	21000	75	219	104	220	660	154	450	1392	203	190	<b>S 61812 E TA</b>
15	19500	15000	23500	100	314	58	300	1023	94	600	2198	132	500	<b>S 61912 C TA</b>
25	18400	14200	20000	150	440	137	460	1396	208	920	2888	276	400	<b>S 61912 E TA</b>
15	10400	8700	29500	50	148	52	160	486	80	310	965	104	330	<b>KH 61912 C TA</b>
25	9800	8200	26500	80	225	109	240	705	161	190	1463	209	280	<b>KH 61912 E TA</b>
15	34400	27100	22000	170	539	75	515	1773	124	1030	3817	175	880	<b>S 6012 C TA</b>
25	32500	25600	18500	270	791	180	810	2457	274	1620	5123	364	700	<b>S 6012 E TA</b>
15	17100	13000	27500	90	261	59	260	796	87	510	1607	115	540	<b>KH 6012 C TA</b>
25	16200	12300	25000	140	405	122	400	1160	177	800	2394	229	465	<b>KH 6012 E TA</b>
15	24900	17000	26000	125	374	56	375	1017	83	750	2501	120	750	<b>SM 6012 C TA</b>
15	24900	17000	31000	125	374	56	375	1017	83	750	2501	120	900	<b>SH 6012 C TA</b>
15	24900	17000	36000	125	374	56	375	1017	83	750	2501	120	1050	<b>SMI 6012 C TA</b>
15	71000	50200	20000	350	1115	90	1000	3473	146	2100	7906	213	1810	<b>S 6212 C TA</b>
25	67700	47400	17000	560	1654	216	1700	5227	333	3400	10863	443	1470	<b>S 6212 E TA</b>
15	12800	11300	22500	65	203	50	190	640	81	400	1450	116	325	<b>S 61813 C TA</b>
25	12000	10600	19500	100	293	122	300	907	182	600	1872	239	265	<b>S 61813 E TA</b>
15	19800	15800	22000	100	313	59	300	1019	96	600	2187	135	510	<b>S 61913 C TA</b>
25	18600	14800	18500	160	469	144	470	1425	215	940	2948	286	400	<b>S 61913 E TA</b>
15	10700	9300	27500	55	158	56	160	490	83	320	1007	110	340	<b>KH 61913 C TA</b>
25	10100	8800	25000	80	223	113	250	724	169	500	1487	219	290	<b>KH 61913 E TA</b>
15	35000	28500	20500	175	550	78	525	1805	128	1050	3878	181	890	<b>S 6013 C TA</b>
25	33000	26800	17500	275	799	187	825	2524	284	1650	5230	376	720	<b>S 6013 E TA</b>
15	17400	13600	26000	90	263	60	260	786	90	520	1635	119	550	<b>KH 6013 C TA</b>
25	16500	12900	23500	140	404	125	410	1181	182	800	2385	235	475	<b>KH 6013 E TA</b>
15	25400	17800	24000	130	373	58	380	1197	91	760	2548	123	750	<b>SM 6013 C TA</b>
15	25400	17800	29000	130	373	58	380	1197	91	760	2548	123	900	<b>SH 6013 C TA</b>
15	25400	17800	34000	130	373	58	380	1197	91	760	2548	123	1050	<b>SMI 6013 C TA</b>
15	73800	54000	18500	370	1172	96	1110	3896	158	2220	8380	225	1900	<b>S 6213 C TA</b>
25	70200	51000	15500	590	1744	228	1760	5413	347	3520	11252	462	1510	<b>S 6213 E TA</b>

Speed values for oil lubrication

Boundary dimensions			Ball		Chamfer		Dimensions							Weight	Designation
d	D	B	D <sub>w</sub>	Z	r <sub>s_min</sub>	r' <sub>s_min</sub>	d <sub>1</sub>	d <sub>2</sub>	d <sub>k</sub>	d <sub>m</sub>	D <sub>1</sub>	D <sub>2</sub>	a	m	
70	90	10	5.556	28	0.6	0.3	76.40	–	79.90	80.00	83.60	85.40	–	0.130	<b>S 61814 C TA</b>
70	90	10	5.556	28	0.6	0.3	76.40	–	79.90	80.00	83.60	85.40	–	0.130	<b>S 61814 E TA</b>
70	100	16	7.938	24	1.0	0.3	80.10	–	85.10	85.00	89.90	92.70	–	0.346	<b>S 61914 C TA</b>
70	100	16	7.938	24	1.0	0.3	80.10	–	85.10	85.00	89.90	92.70	–	0.346	<b>S 61914 E TA</b>
70	100	16	6.350	32	1.0	0.3	80.10	78.45	84.40	85.00	91.25	93.40	–	0.346	<b>KH 61914 C TA</b>
70	100	16	6.350	32	1.0	0.3	80.10	78.45	84.40	85.00	91.25	93.40	–	0.346	<b>KH 61914 E TA</b>
70	110	20	11.906	21	1.1	1.0	82.60	–	90.50	90.00	97.40	101.70	–	0.593	<b>S 6014 C TA</b>
70	110	20	11.906	21	1.1	1.0	82.60	–	90.50	90.00	97.40	101.70	–	0.593	<b>S 6014 E TA</b>
70	110	20	9.525	24	1.1	1.0	82.60	81.10	88.70	90.00	96.70	100.80	–	0.593	<b>KH 6014 C TA</b>
70	110	20	9.525	24	1.1	1.0	82.60	81.10	88.70	90.00	96.70	100.80	–	0.593	<b>KH 6014 E TA</b>
70	110	20	11.906	21	1.1	1.0	82.60	–	90.50	90.00	97.40	101.70	–	0.593	<b>SM 6014 C TA</b>
70	110	20	11.906	21	1.1	1.0	82.60	79.40	90.50	90.00	97.40	101.70	–	0.593	<b>SH 6014 C TA</b>
70	110	20	11.906	21	1.1	1.0	82.60	–	90.50	90.00	97.40	101.70	5	0.593	<b>SMI 6014 C TA</b>

Contact angle	Load rating		Speed value	Light preload			Medium preload			Heavy preload			Spring preload	Designation
	$\alpha_0$	C		$C_0$	n	$F_v$	$F_{a_{max}}$	$C_{ax}$	$F_v$	$F_{a_{max}}$	$C_{ax}$	$F_v$		
15	12900	11700	21500	65	202	51	190	638	82	400	1444	118	335	<b>S 61814 C TA</b>
25	12100	11000	18000	100	292	125	300	905	182	600	1868	245	260	<b>S 61814 E TA</b>
15	24800	20300	20000	130	411	69	379	1269	111	740	2727	156	630	<b>S 61914 C TA</b>
25	23400	19100	17000	200	588	165	590	1798	247	1180	3725	329	510	<b>S 61914 E TA</b>
15	13100	11400	25000	65	190	59	200	602	89	390	1258	118	415	<b>KH 61914 C TA</b>
25	12400	10800	22500	100	290	122	310	898	182	620	1845	235	355	<b>KH 61914 E TA</b>
15	49200	39000	19000	240	750	85	700	2370	140	1400	5100	200	1260	<b>S 6014 C TA</b>
25	46600	36700	16000	400	1170	200	1200	3650	310	2400	7560	420	1010	<b>S 6014 E TA</b>
15	23900	18700	24000	120	351	68	360	1099	104	720	2278	137	760	<b>KH 6014 C TA</b>
25	22700	17600	21500	190	541	143	570	1676	211	1150	3414	274	650	<b>KH 6014 E TA</b>
15	36000	24900	22000	180	537	66	500	1582	99	1000	3300	134	1100	<b>SM 6014 C TA</b>
15	36000	24900	27000	180	537	66	500	1582	99	1000	3300	134	1300	<b>SH 6014 C TA</b>
15	36000	24900	31000	180	537	66	500	1582	99	1000	3300	134	1500	<b>SMI 6014 C TA</b>

Speed values for oil lubrication

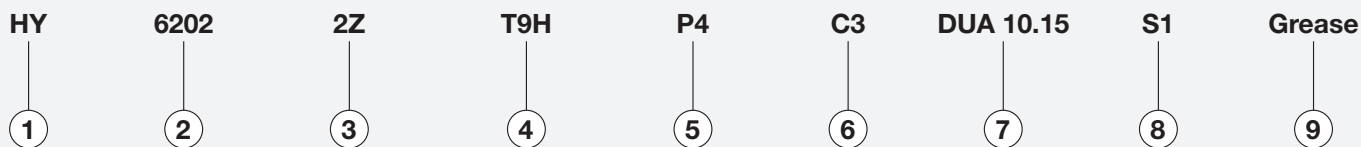

① Material	<p>– Bearings made of chrome steel have no prefix</p> <p><b>M</b> Bearings made of high temperature steel (on request)</p> <p><b>HY</b> Balls and rings from different materials (hybrid bearings)</p>
② Bearing size	<b>6202</b> Designation of dimension series and bore
③ Features Sealing	<p><b>X</b> Oversize bearing</p> <p><b>Z</b> Shield with snap ring on one side of the bearing</p> <p><b>2Z</b> Shields with snap rings on both sides of the bearing, with bearing pairs (matched bearings) shields are on the outside faces</p>
④ Cage	<p><b>J</b> Cage, steel sheet</p> <p><b>T9H</b> Snap cage, glass-fibre-reinforced polyamide, ball riding</p> <p><b>TBH</b> Snap cage, laminated phenolic resin, inner-land-riding</p> <p><b>TA</b> Solid cage, laminated phenolic resin, outer-land-riding</p> <p><b>TB</b> Solid cage, laminated phenolic resin, inner-land-riding</p> <p><b>MA</b> Solid cage, brass, outer-land-riding</p>
⑤ Precision	<p><b>P4</b> Tolerance class P4 according to DIN 620</p> <p><b>P2</b> Tolerance class P2 according to DIN 620</p> <p><b>A7</b> Tolerance class ABEC 7 according to ABMA</p> <p><b>A9</b> Tolerance class ABEC 9 according to ABMA</p> <p><b>HG</b> GMN high precision according to GMN specification</p> <p><b>UP</b> GMN ultra precision according to GMN specification</p>
⑥ Bearing clearance	<p><b>C2</b> Radial clearance smaller than normal</p> <p>– Normal clearance (not shown in code)</p> <p><b>C3</b> Radial clearance greater than normal</p> <p><b>C4</b> Radial clearance greater than C3</p> <p>Reduced ranges of radial clearance are noted in clear (values without measuring load)</p>
⑦ Matched bearings	<p><b>DF</b> Face-to-face arrangement</p> <p><b>DB</b> Back-to-back arrangement</p> <p><b>DT</b> Tandem arrangement</p> <p><b>DUA</b> Universally matched with axial clearance</p> <p><b>DUO</b> Universally matched without axial clearance</p> <p><b>DUV</b> Universally matched with preload</p>
⑧ Heat treatment	<p><b>S1</b> Operating temperature up to +200 °C</p> <p><b>S2</b> Operating temperature up to +250 °C</p> <p><b>S3</b> Operating temperature up to +300 °C</p>
⑨ Lubrication	Designation of grease, e.g. <b>Asonic GLY 32</b>

## Deep groove bearings

The following notations are used in the bearing tables:

d	[mm]	Bore diameter
D	[mm]	Outer diameter
B	[mm]	Width, single bearing
$r_{smin}$	[mm]	Chamfer
$D_w$	[mm]	Ball diameter
Z	[Stück]	Ball complement
m	[kg]	Weight
$d_m$	[mm]	Pitch circle diameter
$d_1$	[mm]	Outer diameter of inner ring
$D_1$	[mm]	Inner diameter of outer ring
n	[1/min]	Speed value
C	[N]	Dynamic load rating
$C_0$	[N]	Static load rating

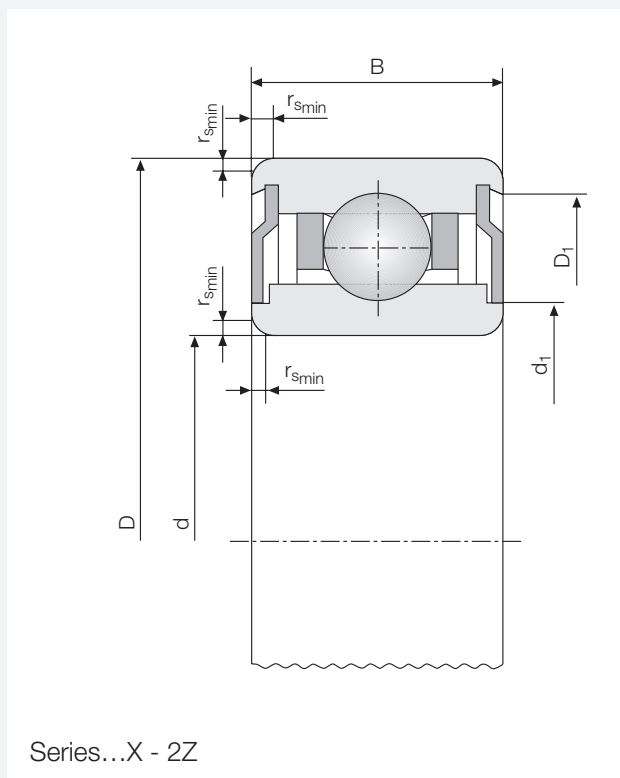
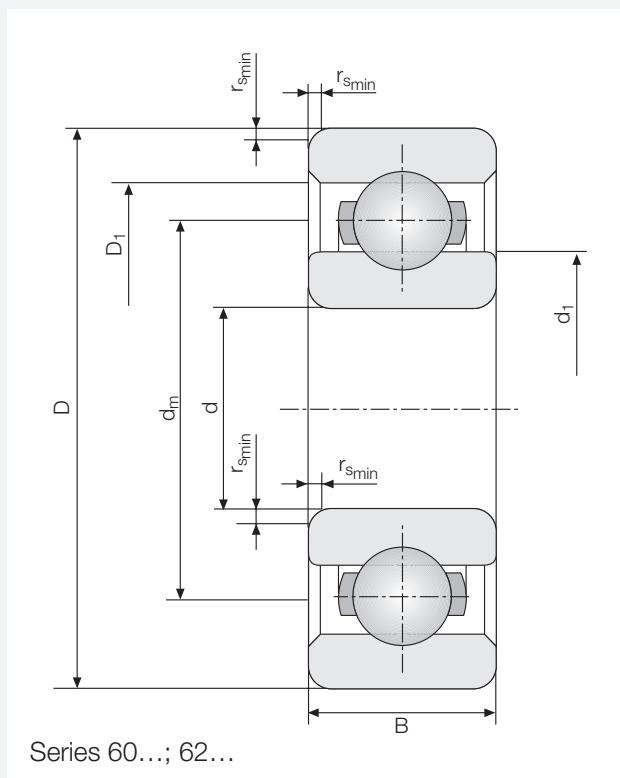

Boundary dimensions			Ball		Chamfer	Dimensions		Designation
d	D	B	D <sub>w</sub>	Z	r <sub>smin</sub>	d <sub>1</sub>	D <sub>1</sub>	
5	16	5	3.175	6	0.3	7.65	12.50	<b>625</b>
6	19	6	3.175	8	0.3	10.70	15.80	<b>626</b>
7	19	6	3.175	8	0.3	10.70	15.80	<b>607</b>
7	22	7	3.969	7	0.3	11.80	17.60	<b>627</b>
8	22	7	3.969	7	0.3	11.80	17.60	<b>608</b>
8	22	10.312	3.969	7	0.3	10.50	19.00	<b>608 X - 2Z</b>
9	24	7	3.969	8	0.3	13.45	19.90	<b>609</b>
9	26	8	4.762	7	0.3	14.65	21.40	<b>629</b>
10	26	8	4.762	7	0.3	14.65	21.40	<b>6000</b>
10	30	9	5.556	7	0.6	16.00	24.45	<b>6200</b>
10	26	11.506	4.762	7	0.3	13.00	23.10	<b>6000 X - 2Z</b>
12	28	8	4.762	8	0.3	16.65	23.40	<b>6001</b>
12	32	10	5.953	7	0.6	18.30	26.00	<b>6201</b>
12	28	11.506	4.762	8	0.3	15.00	25.10	<b>6001 X - 2Z</b>
15	32	9	4.762	9	0.3	20.15	26.90	<b>6002</b>
15	35	11	5.953	8	0.6	21.10	29.00	<b>6202</b>
15	32	11.506	4.762	9	0.3	18.50	28.45	<b>6002 X - 2Z</b>
17	35	10	4.762	10	0.3	22.65	29.40	<b>6003</b>
17	40	12	6.747	8	0.6	24.10	32.95	<b>6203</b>
17	35	12.700	4.762	10	0.3	21.00	30.95	<b>6003 X - 2Z</b>
20	42	12	6.350	9	0.6	26.60	35.45	<b>6004</b>
20	47	14	7.938	8	1.0	28.50	38.55	<b>6204</b>
20	42	15.875	6.350	9	0.6	24.30	37.00	<b>6004 X - 2Z</b>
25	47	12	6.350	10	0.6	32.20	40.05	<b>6005</b>
25	52	15	7.938	9	1.0	34.04	44.05	<b>6205</b>
30	55	13	7.144	11	1.0	38.10	46.95	<b>6006</b>
30	62	16	9.525	9	1.0	40.40	52.05	<b>6206</b>
35	72	17	11.112	9	1.1	47.40	60.55	<b>6207</b>
40	80	18	11.906	9	1.1	52.80	67.60	<b>6208</b>



Load rating		Speed value	Pitch diameter	Weight	Designation
C	C <sub>0</sub>	n	d <sub>m</sub>	m	
1800	665	46000	10.5	0.005	<b>625</b>
2300	935	43000	12.5	0.008	<b>626</b>
2300	935	43000	13.0	0.008	<b>607</b>
3000	1290	40500	14.5	0.012	<b>627</b>
3000	1290	40500	15.0	0.012	<b>608</b>
3000	1290	65000	15.0	0.014	<b>608 X - 2Z</b>
3350	1400	37000	16.5	0.023	<b>609</b>
4500	1850	35000	17.5	0.020	<b>629</b>
4500	1850	34500	18.0	0.019	<b>6000</b>
6100	2600	31000	20.0	0.032	<b>6200</b>
4500	1850	55000	18.0	0.024	<b>6000 X - 2Z</b>
4900	2150	31000	20.0	0.022	<b>6001</b>
6900	3000	28000	22.0	0.037	<b>6201</b>
4900	2150	50000	20.0	0.027	<b>6001 X - 2Z</b>
5400	2500	26500	23.5	0.030	<b>6002</b>
7700	3500	25000	25.0	0.045	<b>6202</b>
5400	2500	42000	23.5	0.034	<b>6002 X - 2Z</b>
5800	2800	24000	26.0	0.039	<b>6003</b>
9600	4500	22000	28.5	0.065	<b>6203</b>
5800	2800	38000	26.0	0.046	<b>6003 X - 2Z</b>
9900	4900	20000	31.0	0.069	<b>6004</b>
14100	7000	18000	33.5	0.106	<b>6204</b>
9900	4900	32000	31.0	0.070	<b>6004 X - 2Z</b>
10700	5600	17000	36.0	0.080	<b>6005</b>
15400	8000	16000	38.5	0.128	<b>6205</b>
13500	7400	14500	42.5	0.128	<b>6006</b>
20400	10900	13500	46.0	0.199	<b>6206</b>
28000	15500	11500	53.5	0.315	<b>6207</b>
29700	16600	10000	60.0	0.402	<b>6208</b>

Speed values for grease lubrication.  
 With Z- or 2Z- execution standard grease used is  
 KLÜBER Asonic GLY 32; greasefill 30% of void space  
 (other types of grease or greasefill on request).

## Special Solutions

### Special bearings / units

#### From idea to solution

In addition to the main program, GMN also offers the possibility to find new solutions thanks to its engineering and flexible manufacturing areas. The products range from special bearings to ready-to-install bearing systems. After sales service and the continuous development of existing products set GMN apart from the competition.

Technical benchmarks that are founded on detailed basic developments are set for various applications:

- Vacuum applications (TMP, SEM)
- Medical technology (X-ray tube bearing units)
- Touchdown bearings for magnetic bearing systems
- Laser technology
- Measurement and navigation bearings and units
- Machine tool applications

### Technology

#### GMN: proven success

The continuous development of key competences, committed employees, a real sense of quality and the careful selection of suppliers are guarantees of delivery dependability and quality.

The use of the most modern technology such as CBN grindings, hard turning and PVD sputtering form the basis for flexible solutions at the cutting edge of technology.

The assembly in clean room conditions completes the possibilities that GMN offers.

### Engineering / Service

#### The start of a series is not the end

Innovative products require close team work with customers, universities and qualified industrial partners from the concept phase through to the finished product series.

The complete technical knowledge of the company is utilised from the very start and modern methods such as 6-Sigma, Design-To-Cost, SEM and TEM are implemented.

The result is a technically innovative, cost-optimised product that is supervised from development through to series production.



GMN PVD sputtering system

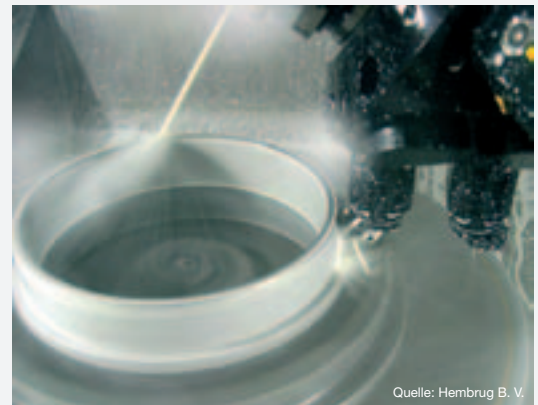

Quelle: Hembrug B. V.

High-end manufacturing

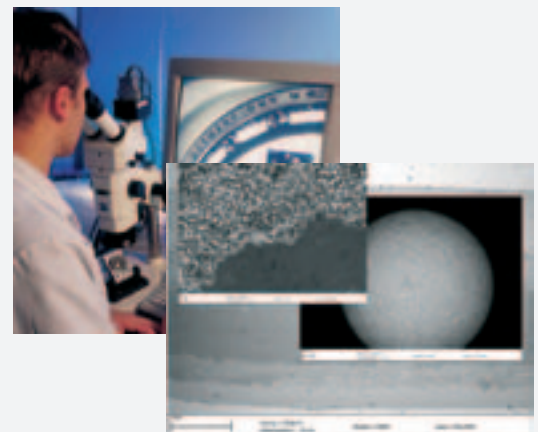

After sales service

## Example applications

### Vacuum technology

#### Medical technology (x-ray)

- Full complement ball bearing systems
- Dry lubrication
- Temperatures up to 550°C
- High vacuum up to  $10^{-9}$  mbar

#### Turbo molecular pumps

- Shielded special design bearings
- Long service life
- Optimised lubrications

### Touchdown bearings

- Full complement ball bearing
- Adapted tribology
- High acceleration to final speed
- Ceramic balls

### Measurement technology

- Ready-to-install, preloaded bearing systems
- High running accuracy
- Low frictional moments
- Defined system rigidity
- Precision associated components

### Machine tools

- Special designs
- High speeds
- Special materials
- Special cages



## Dictionary English – German

### Technical vocabulary

Abrasive wear	abrasiver Verschleiß
Abutment face	Anlageschulter
Additional coding	Zusatzzeichen
Adjusted bearing mounting	angestellte Lagerung
Adjustment	Anstellung
Aging of lubricant	Alterung des Schmierstoffes
Angular contact bearing	Schräggugellager
Angle error	Winkelfehler
Associated component	Umbauteil
Axial clearance	Axialluft
Axial force	Axialkraft
Axial load carrying capacity	axiale Belastbarkeit
Axial load factor Y, Yo	Axialfaktor Y, Yo
Axial runout	Axialschlag
Back to back mounting	O-Anordnung
Basic oil	Grundöl
Basic rating life	Nominelle Lebensdauer
Bearing force	äußere Kraft
Bearing order reference	Bestellbezeichnung
Bearing preload	Lagervorspannung
Bearing seat	Lagersitz
Bearing suffix	Nachsetzzeichen
Bearing temperature	Lagertemperatur
Body resonance	Körperschall
Cage	Käfig
Centrifugal force	Fliehkraft
Chamfer dimension	Kantenabstand
Coefficient of expansion	Ausdehnungskoeffizient
Coefficient of thermal expansion	Wärmeausdehnungskoeffizient
Collective bearing loading	Belastungskollektiv
Combined bearing loading	kombinierte Belastung
Connecting dimension	Anschlußmaß
Contact angle	Druck-, Anlaufwinkel
Contact angle line	Drucklinie
Contact ellipse	Druckellipse
Contact pressure	Flächenpressung
Covering part	Umbauteil
Critical rotational speed	kritische Drehzahl
Deep groove ball bearing	Rillenkugellager
Deformation	Aufweitung, Verformung
Dimensional accuracy	Maßgenauigkeit
Dimensional series	Maßreihe
Design of bearing application	Gestaltung der Lagerung
Dynamic load rating	dynamische Tragzahl
Endplay	Axialspiel
Equivalent load	äquivalente Belastung

## Dictionary English – German

Face to face mounting	X-Anordnung
Faulty mounting	Einbaufehler
Fit	Passung
Fixed bearing	Festlager
Floating bearing	Loslager
Force	Kraft
Force flow	Kraftfluß
For life lubrication	Lebensdauerschmierung
Form accuracy	Formgenauigkeit
Form irregularity	Formfehler
Form tolerance	Formtoleranz
Frequency analysis	Frequenzanalyse
Friction	Reibung
Friction limit	Grenzreibung
Frictional wear	Reibverschleiß
High temperature steel	warmfester Stahl
Initial greasing	Erst-Befettung
Internal design	Innenkonstruktion
Internal force	innere Kraft
Injection oiling	Einspritzschmierung
Land diameter	Borddurchmesser
Life time	Lebensdauer
Line contact	Linienberührung
Load	Belastung
Load carrying capacity	Belastbarkeit
Load distribution	Lastverteilung
Loading	Belastung
Loading set point	Lastangriff
Lubrication	Schmierung
Material	Werkstoff
Minimum bearing loading	Mindestbelastung
Misalignment	Fluchtfehler, Schrägstellung
Modified life	modifizierte Lebensdauer
Mounting	Montage
Mounting dimension	Einbaumaß
Noise	Geräusch
Noiseless bearing	geräuscharmes Lager
Noise test	Geräuschprüfung
Non separable bearing	nicht zerlegbares Lager
Operating clearance	Betriebslagerluft, -spiel
Operating temperature	Betriebstemperatur
Outside diameter	Außen-, Manteldurchmesser
Out of roundness	Unrundheit
Oversize	Übermaß
Part number system	Bezeichnungssystem
Permanent lubrication	Dauerschmierung
Pitch circle diameter	Teilkreisdurchmesser
Plane accuracy	Planlauf
Point contact	Punktberührung
Polyurea	Polyharnstoff
Precision grade	Genauigkeitsklasse
Preload	Vorspannung
Pressed cage	Blechkäfig
Probability of failure	Ausfallwahrscheinlichkeit

## Dictionary English – German

Quality assurance	Qualitätssicherung
Raceway curvature	Schmiegung
Radial load factor X, X <sub>o</sub>	Radialfaktor X, X <sub>o</sub>
Reaction force	Auflagekraft
Referenced operational viscosity	Betriebsviskosität
Rigidity	Steifigkeit, Starrheit
Rolling conditions	Abwälzverhältnisse
Rotational speed limit	Drehzahlgrenze
Roughness	Rauhigkeit, Rauhtiefe
Running accuracy	Laufgenauigkeit
Separable bearing	zerlegbares Lager
Service life	Gebrauchsdauer
Shield	Deckscheibe
Side runout	Seitenschlag
Silicone grease	Silikonfett
Sliding friction	Gleitreibung
Snap ring	Sprengtring
Solid cage	Massivkäfig
Spacer	Distanzring
Speed	Drehzahl
Speed coefficient	Drehzahlkennwert
Spindle bearing	Spindellager
Spinning force	Kreiselkraft
Spinning friction	Bohrreibung
Spread	Stützbreite
Spring characteristic curve	Federkennlinie
Starting friction	Anlaufreibung
Static load rating	statische Tragzahl
Static loading	statische Belastung
Stiffness	Steifigkeit
Supporting base	Stützbasis
Surface plating	Oberflächenbeschichtung
Survival probability	Überlebenswahrscheinlichkeit
Talyrond diagram	Talyrond Diagramm
Tandem bearing mounting	Tandem-Anordnung
Temperature	Temperatur
Tolerance zone	Toleranzfeld
Unbalanced loading	Belastung durch Unwucht
Vibration	Körperschall, Schwingung
Viscosity	Viskosität
Wall thickness	Wandstärke
Width variation	Breitenschwankung
Working pressure angle	Betriebsdruckwinkel
Young's modulus	Elastizitätsmodul

# PRODUCT RANGES

## High Precision Ball Bearings

GMN produces high precision ball bearings in precision class P4 (ABEC7) or better as spindle bearings (angular contact bearings), radial deep groove ball bearings as well as hybrid bearings and special bearings.

Complete units with additional installation parts according to customer's wish supplement the product range.

GMN coats bearings and other parts, e.g. for solid lubrication in vacuum technique in a company-own PVD unit.

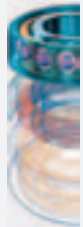

## Spindles

GMN machine spindles represent more than 70 years of experience in development, production and application. They are used for precision as well as for HSC high-speed processing. A close-knit network of dealers and repair service workshops guarantees comprehensive service and expert advice.

GMN optospindles, air bearings and scanners are setting new standards in image projection. They have been developed for maximum running accuracy as well as stability in rotational speed and phase.



## Freewheel-Clutches

Freewheels are unidirectional couplings, transmitting or supporting torque in one direction by friction and allowing idling in the opposite direction.

GMN manufactures sprag type clutches of two different sprag sizes to be used as indexing devices, backstops or overrunning clutches. Roller ramp supplements are available too.



## Non-Contact Seals

GMN offers two different systems of non-contact seals for wear free sealing of fast turning machine components.

The GMN labyrinth seals are made from steel and aluminium by a special and very sophisticated production process which results in absolute identity of the inner and outer rings labyrinth profile.

The GMN gap seals with return drain are made from high quality, highly resistant plastic material.





**High Precision  
Ball Bearings**

Spindle Bearings

Deep Groove Ball Bearings

Hybrid Bearings

Special Bearings,  
Bearing Units

Vacuum Technology,  
Dry Lubrication



**GMN Paul Müller Industrie  
GmbH & Co. KG**

Äußere Bayreuther Straße 230  
D - 90411 Nürnberg

Phone: +49 (0) 9 11 - 56 91 - 2 25 / 2 29 / 2 17 / 3 26

Fax: +49 (0) 9 11 - 56 91 - 5 87

Email: [vertrieb.kula@gmn.de](mailto:vertrieb.kula@gmn.de)

Internet: [www.gmn.de](http://www.gmn.de)